

# 8900 Proportioner

309790ZAE

EN

**Configured product offering for dispensing fixed or variable ratio of two fluids. For professional use only.  
Not approved for use in European explosive atmosphere locations.**

*2000 psi (13.8 MPa, 138 bar) Maximum Working Pressure*



### Important Safety Instructions

Read all warnings and instructions in this manual.  
Save these instructions.

See page 8 for pump model numbers, ratios and working pressures.

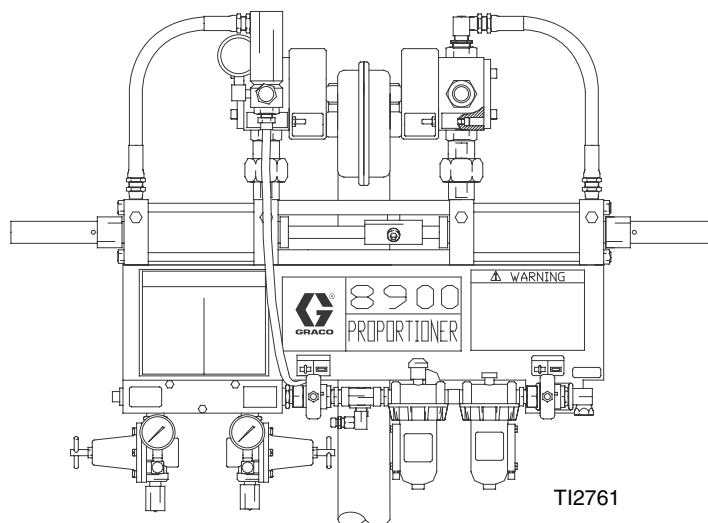

Fixed-ratio proportioner shown





# Contents







<b>Warnings</b> .....	<b>4</b>	<b>Parts</b> .....	<b>48</b>
<b>Theory of Operation</b> .....	<b>6</b>	8900 Proportioner, Fixed Ratio .....	48
Use .....	6	8900 Proportioner, Variable Ratio .....	50
Major Components .....	6	Cylinder Assemblies .....	52
Ratio Proportioning .....	6	Limit Valve .....	53
System Components and Operation Overview ..	6	Air Control .....	54
<b>Models</b> .....	<b>8</b>	4-Way Valve .....	55
<b>Installation</b> .....	<b>10</b>	Pump Feed Module Selection for Component A or Component B .....	56
Typical Installation .....	10	20:1 President on 5 Gallon Ram .....	56
Location .....	10	34:1 Senator on 5 Gallon Ram .....	58
Ground .....	12	23:1 Monark on 5 Gallon Ram .....	60
Flush .....	13	20:1 NXT (700/60) on 55 Gallon Ram .....	62
<b>Setup</b> .....	<b>14</b>	40:1 NXT (2200/100) on 55 Gallon Ram .....	64
Set the Ratio (variable ratio models only) .....	14	23:1 NXT (2200/200) on 55 Gallon Ram .....	65
Output Charts/Ratio Settings .....	15	20:1 Senator on 55 Gallon Drum .....	66
Before You Load Material .....	18	9:1 DynaMite on 1 Gallon Can Ram .....	67
Load Component A .....	19	10 Gallon Press Tank with 15:1 Booster .....	68
Prime Pump A .....	20	10:1 President 5 Gallon Pail Cover .....	69
Load Component B .....	21	Mix Kit Selection .....	70
Prime with Component B .....	24	Cartridge Fill Medium Viscosity Wide Ratio ...	70
Fill the 8900 Proportioner with Material .....	24	Cartridge Fill High Viscosity Wide Ratio .....	72
<b>Operation</b> .....	<b>27</b>	Brush Grade High Viscosity Wide Ratio .....	74
Pressure Relief Procedure .....	27	MD2 20 ft Automatic .....	76
Dispense Mixed Material .....	28	MD2 20 ft Hand Gun .....	77
Changing Component A Drum .....	30	MD2 15 ft Hand Gun Wide Ratio Moisture Lock	78
Changing Component B Pail .....	31	High Volume Static Mix Manifold .....	79
Filling Component B Pressure Tank .....	32	High Volume Static Mix Kit with Pump Pilots ...	80
Daily Procedures .....	34	Stanchion .....	81
<b>Troubleshooting</b> .....	<b>36</b>	Boom Assembly .....	82
8900 Proportioner Operating Pressures .....	36	<b>Technical Data</b> .....	<b>84</b>
Air Supply Troubleshooting Chart .....	37	<b>Graco Standard Warranty</b> .....	<b>86</b>
Pump Troubleshooting Overview .....	38	<b>Graco Information</b> .....	<b>86</b>
Troubleshooting Guide: Feed pumps .....	39		
Troubleshooting Guide: 8900 Proportioner ....	40		
Troubleshooting Guide: Manifold/Mixer .....	41		
Preventive Maintenance .....	42		
<b>Service and Repair</b> .....	<b>43</b>		
Repair the Cylinder (Fixed Ratio) .....	43		
Replace Air Valve .....	45		
<b>Disassemble Fluid Valve</b> .....	<b>46</b>		



A series of horizontal lines for writing, consisting of 25 evenly spaced lines extending across the width of the page.

## Warnings

 <b>Warning</b>	
 	<p><b>Skin Injection Hazard</b></p> <p>Spray from the gun, hose leaks, or ruptured components can inject fluid through skin and cause extremely serious injury, including need for amputation. Fluid splashed in the eyes or on skin can cause serious injury.</p> <ul style="list-style-type: none"> <li>• Fluid injected into skin might look like just a cut, but it is a serious injury. <b>Get immediate surgical treatment.</b></li> <li>• Do not point the gun at anyone or any part of the body.</li> <li>• Do not put hand or fingers over the spray tip/nozzle.</li> <li>• Do not stop or deflect leaks with hand, body, glove or rag.</li> <li>• Do not “blow back” fluid; this is not an air spray system.</li> <li>• Always have tip guard and trigger guard on the gun when spraying.</li> <li>• Check gun diffuser weekly. Refer to gun manual.</li> <li>• Check trigger safety operation before spraying. Lock trigger safety when you stop spraying.</li> <li>• Follow the <b>Pressure Relief Procedure</b>, page 27, if the spray tip/nozzle clogs and before cleaning, checking or servicing the equipment.</li> <li>• Tighten fluid connections before operating equipment.</li> <li>• Check hoses, tubes, and couplings daily. Replace worn or damaged parts immediately. Do not repair high pressure couplings; replace the entire hose.</li> <li>• Fluid hoses must have spring guards on both ends to help protect them from rupture caused by kinks or bends near the couplings.</li> </ul>
 	<p><b>Toxic Fluid Hazard</b></p> <p>Hazardous fluids or toxic fumes can cause serious injury or death if splashed in the eyes or on skin, swallowed, or inhaled.</p> <ul style="list-style-type: none"> <li>• Know specific hazards of the fluid. Read fluid manufacturer’s warnings.</li> <li>• Wear appropriate protective clothing, gloves, eyewear, and respirator.</li> </ul>

Warning	
  	<p><b>Equipment Misuse Hazard</b></p> <p>Equipment misuse can cause equipment to rupture, malfunction, or start unexpectedly and cause serious injury.</p> <ul style="list-style-type: none"> <li>• This equipment is for professional use only.</li> <li>• Read manuals, tags, and labels before operating equipment.</li> <li>• Use equipment only for its intended purpose. If you are uncertain, call your Graco distributor.</li> <li>• Do not alter or modify equipment. Use only genuine Graco parts and accessories.</li> <li>• Check equipment daily. Repair or replace worn or damaged parts immediately.</li> <li>• Do not exceed maximum working pressure of lowest rated system component.</li> <li>• Use fluids and solvents that are compatible with equipment wetted parts. See <b>Technical Data</b> section of all equipment manuals. Read fluid and solvent manufacturer's warnings.</li> <li>• Route hoses away from traffic areas, sharp edges, moving parts, and hot surfaces. Do not expose Graco hoses to temperatures above 180°F (82°C) or below -40°F (-40°C).</li> <li>• Do not kink or overbend hoses or use hoses to pull equipment.</li> <li>• Comply with all applicable local, state, and national fire, electrical, and other safety regulations.</li> <li>• Do not use excessive drum separation air pressure as the drum could rupture. Make sure the drum is not damaged and the ram plate is free to exit the drum before applying air pressure.</li> </ul>
 	<p><b>Fire and Explosion Hazard</b></p> <p>Improper grounding, poor ventilation, open flames or sparks can cause a hazardous condition and result in fire or explosion and serious injury.</p> <ul style="list-style-type: none"> <li>• Ground the equipment and object being sprayed. See <b>Grounding</b>, page 12.</li> <li>• If you experience static sparking or electric shock, <b>stop operation immediately</b>. Identify and correct the problem.</li> <li>• Provide fresh air ventilation to avoid building up flammable fumes.</li> <li>• Keep the spray area free of debris, including solvent, rags, and gasoline.</li> <li>• Extinguish all sources of flames in the spray area, including pilot lights and cigarettes.</li> <li>• Do not turn on or off any light switch or plug or unplug electrical equipment in the spray area while operating or if fumes are present.</li> <li>• Do not operate a gasoline engine in the spray area.</li> <li>• Keep a fire extinguisher in the work area.</li> </ul>
 	<p><b>Moving Parts Hazard</b></p> <p>Moving parts, such as priming piston and wiper plate, can pinch or amputate fingers. Keep clear of moving parts when starting or operating equipment and when equipment is pressurized.</p> <ul style="list-style-type: none"> <li>• Keep hands and fingers away from the priming piston.</li> <li>• Keep hands away from the ram wiper plate and pail lip.</li> <li>• Before servicing, follow the <b>Pressure Relief Procedure</b>, page 27, to avoid equipment startup.</li> </ul>

# Theory of Operation

## Use

The 8900 Proportioner is used with two component materials where one or both components is high viscosity. This is typically found in the sealant and adhesive industry, where special requirements for loading and pumping necessitate the use of the 8900 proportioning system.

## Major Components

The major components of the 8900 Proportioner system include the:

- Component A or major volume metering cylinder
- Component B or minor volume metering cylinder
- Component A or major volume feed supply
- Component B or minor volume feed supply

## Ratio Proportioning

The A and B cylinders are positive displacement metering cylinders. Positive displacement cylinders displace a defined volume of fluid for a given stroke length.

On fixed ratio units, the volumetric ratio is the ratio of the area of the component A displacement cylinder to the area of the component B displacement cylinder. At a 1:1 ratio, the displacement cylinders are the same size. On higher ratio units the component A cylinder is usually the larger of the two. The ratio of the components is the difference in effective area between the cylinders.

On variable ratio units, the component B cylinder has an adjustable stroke length. The component A cylinder has a fixed stroke length. By setting the stroke adjustment to different points on the connecting linkage, you can change the stroke length of the B cylinder, which changes the mix ratio. You can calculate the material mix ratio from the ratio of the cylinder displacement volume.

Note that the mix ratio of the 8900 Proportioner is achieved by volumetric ratio of component A to component B and not by weight. These two ratios are often different depending on material properties.

## System Components and Operation Overview

### Feed Systems - Feed Pumps

#### Load the Feed Pumps and Proportioner

The A and B feed pumps/cylinders must completely fill (prime) on both strokes to ensure accurate material displacement.

With high viscosity materials, it is difficult for material to flow into the pump. Individual feed pumps are used to supply these materials under pressure to the 8900 Proportioner. When air is trapped in the feed system due to improper loading, a condition called cavitation occurs.

If cavitation occurs, part of the downstroke will be used to fill the vacuum before any material is actually displaced. Since the total stroke length is used to calculate mix ratio, this may result in an off-ratio condition.

To prevent cavitation with higher viscosity materials, both cylinders are pressure fed. The A pump is pressurized by a pneumatic ram supply unit applying a downward force on a 55-gallon plate fitted into the drum. A shovel action pump fluid inlet further aids in pump priming. Component B is delivered to the B pump by pressure fed 5- or 55-gallon supply modules, depending on the volumetric ratio of the material.

Pneumatic ram assisted feed pumps may not be required for lower viscosity materials.

### Feed Systems - Alternative Feed Supplies

Header or other feed systems may be used to supply A and B materials to the 8900 Proportioner. Generally these feed systems are provided by others and are not addressed in this manual. This manual applies only to the Graco Configured 8900 Proportioner system.

## Pump Fluids to the Mixer

Fluid is pumped through the proportioner to a mix chamber or to a 2-component dispense gun, where component A and component B are first introduced before being mixed with a static mixer.

A fluid injector nozzle/check valve injects component B into component A at the mix chamber. When enough pressure builds up, the check valve opens and component B flows into the mix chamber. This means that during flow conditions with two positive displacement cylinders linked together, the pressures at the mix point are equal.

Any pressure differences noted on the gauges while running, reflect differences in the pressure lost by each fluid getting from the gauge to the mix point. These pressure drops are caused by hoses and fittings in conjunction with material viscosity.

## Mix the Fluids

Both components leave the mix chamber and enter a static mixer where they are mixed to a homogeneous blend. The mixer consists of a series of left and right-hand spiral elements. This is true for both mix chamber and 2-component mix gun.

When the components are pumped through the mixer, they are progressively divided and recombined. Static mixers used on the 8900 Proportioner system include the tri-core mixer, flexible hose mixer, or disposable mixer.

## Ratio Checks

On the variable ratio model, a ratio check station option verifies the volumetric mix ratio of the two components. It is located at the outlet blocks. With all outbound fluid valves closed, each component flows through individual ball valves opened by a common handle into containers.

Volumetric mix ratio can be calculated from the weight of each component or by direct measurement. Ratio checks are performed with the back pressures set to actual operating pressures to simulate the normal back pressures created by the mix chamber and gun.

## Dispense Valve

An *extrusion flow gun* is commonly used as the application device. It has a final or clean up mixer installed in the handle. Various extrusion nozzles are available for caulking or sealing applications.

Some 8900 Proportioners use a *2K disposable mixer element dispense valve* instead of the flow gun.



The 8900 Proportioner can be used in automatic assembly lines with the addition of a logic interface.

# Models



Refer to form 684041 for selection information.

<b>Model</b>	<b>Description</b>	
890-D	Power Valved Passive Proportioner	
<b>Code A</b>	<b>Proportioner Selection (“A” Cyl. / “B” Cyl.)</b>	<b>Module Number</b>
1	1:1 Fixed (1000/1000)	570371
2	2:1 Fixed (1000/500)	570372
3	2.5:1 Fixed (250/100)	570373
4	4:1 Fixed (1000/250)	570374
5	5:1 Fixed (500/100)	570375
6	10:1 Fixed (1000/100)	570376
7	9:1 Fixed (1000/111)	246557
A	1:1 to 4:1 Variable (500/500)	570377
B	2:1 to 8:1 Variable (500/250)	570378
D	5:1 to 20:1 Variable (500/100)	570380
<b>Code B</b>	<b>Pump Feed Module Selection for Component A</b>	<b>Module Number</b>
A	20:1 President on 5 Gallon Ram	965571
B	34:1 Senator on 5 Gallon Ram	965597
C	23:1 Monark on 5 Gallon Ram	570142
D	20:1 NXT (700/60) on 55 Gallon Ram	570114
E	40:1 NXT (2200/100) on 55 Gallon Ram	965572
F	23:1 NXT (2200/200) on 55 Gallon Ram	570141
G	20:1 Senator on 55 Gallon Drum	570309
H	9:1 DynaMite 1 Gallon Can Ram	570249
J	10 Gallon Press Tank with 15:1 Booster	570037
K	10:1 President 5 Gallon Pail Cover	570264
N	None	
<b>Code C</b>	<b>Pump Feed Module Selection for Component B</b>	<b>Module Number</b>
A	20:1 President on 5 Gallon Ram	965571
B	34:1 Senator on 5 Gallon Ram	965597
C	23:1 Monark on 5 Gallon Ram	570142
D	20:1 Check-Mate on 55 Gallon Ram	570114
E	34:1 Check-Mate on 55 Gallon Ram	965572
F	23:1 Check-Mate on 55 Gallon Ram	570141
G	20:1 Senator on 55 Gallon Drum	570309
H	9:1 DynaMite 1 Gallon Can Ram	570249
J	10 Gallon Press Tank with 15:1 Booster	570037
K	10:1 President 5 Gallon Pail Cover	570264
N	None	

<b>Code D</b>	<b>Mix Kit Selection</b>	<b>Module Number</b>
1	Cart Fill Medium Viscosity Wide Ratio	570248
2	Cart Fill High Viscosity Wide Ratio	570318
3	Brush Grade High Viscosity Wide Ratio	570358
4	MD2 20 ft Automatic Wide Ratio	24H258
5	MD2 20 ft Automatic Close Ratio	24H259
6	MD2 20 ft Hand Gun Wide Ratio	24H260
7	MD2 20 ft Hand Gun Close Ratio	24H261
8	MD2 15 ft Hand Gun Wide Ratio Moisture Lock	24H243
9	High Volume Static Mix Kit with Pump Pilots	570263
N	None	
<b>Code E</b>	<b>Mounting Type Selection</b>	<b>Module Number</b>
1	Stanchion	570071
2	Boom Assembly	246589
N	None (mount on 3 in. 55 gallon ram)	

# Installation

## Typical Installation

Figures 1-3 are only guides for selecting and installing system components and accessories. Contact your Graco distributor for assistance in designing a system to suit your needs.

## Location

Position the feed modules so the pump and ram are easily accessible. Ensure that there is sufficient overhead clearance when the ram is fully raised. Refer to the ram manual for clearance dimensions.

Check that the ram base is level in all directions. If necessary, level the base using metal shims. Secure the base to the floor using 1/2 in. (13 mm) anchors that are long enough to prevent the ram from tipping.

Using the holes in the ram base as a guide, drill four holes for 1/2 in. (13 mm) anchors.

### Key: Figs. 1 and 2

- |   |   |   |  |
|---|---|---|--|
| A | System Air Shutoff Valve (bleed-type)     | L | Component A and Component B Feed Pump Air Motor Lubricator |
| B | Main Air Filter                           | M | Component B Ram Plate with Vent Stick or Valve             |
| C | Component B Ram Directional Valve         | N | Component A Ram Plate with Drum Vent Valve                 |
| D | Component B Ram Air Pressure Regulator    | O | Component A Pump Air Regulator                             |
| E | Component B Air Supply Valve (bleed-type) | P | Component A Ram Directional Valve                          |
| F | Component B Air Supply Regulator          | Q | MD2 Gun with Disposable Mixers                             |
| G | Component A Air Supply Valve              | R | Component A Ram Air Pressure Regulator                     |
| H | Component B Outlet Pressure Gauge         | S | Accessory/Gun Air Supply Valve                             |
| J | Component B Feed Pressure Gauge           |   |  |
| K | Component A Feed Pressure Gauge           |   |  |

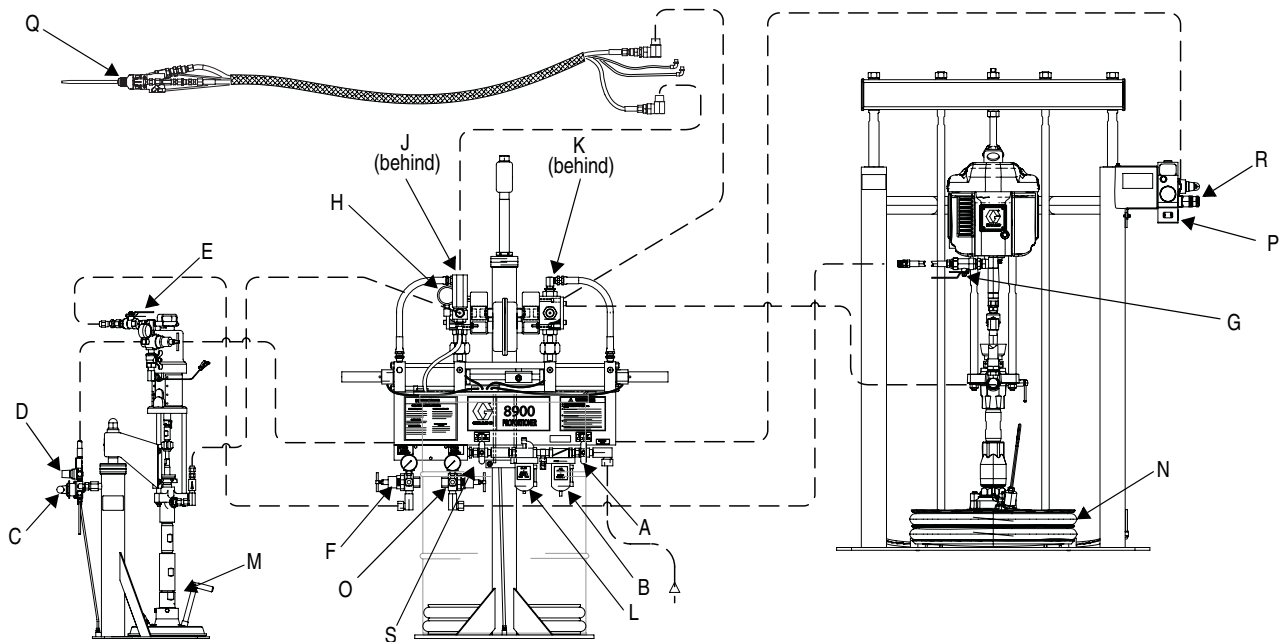
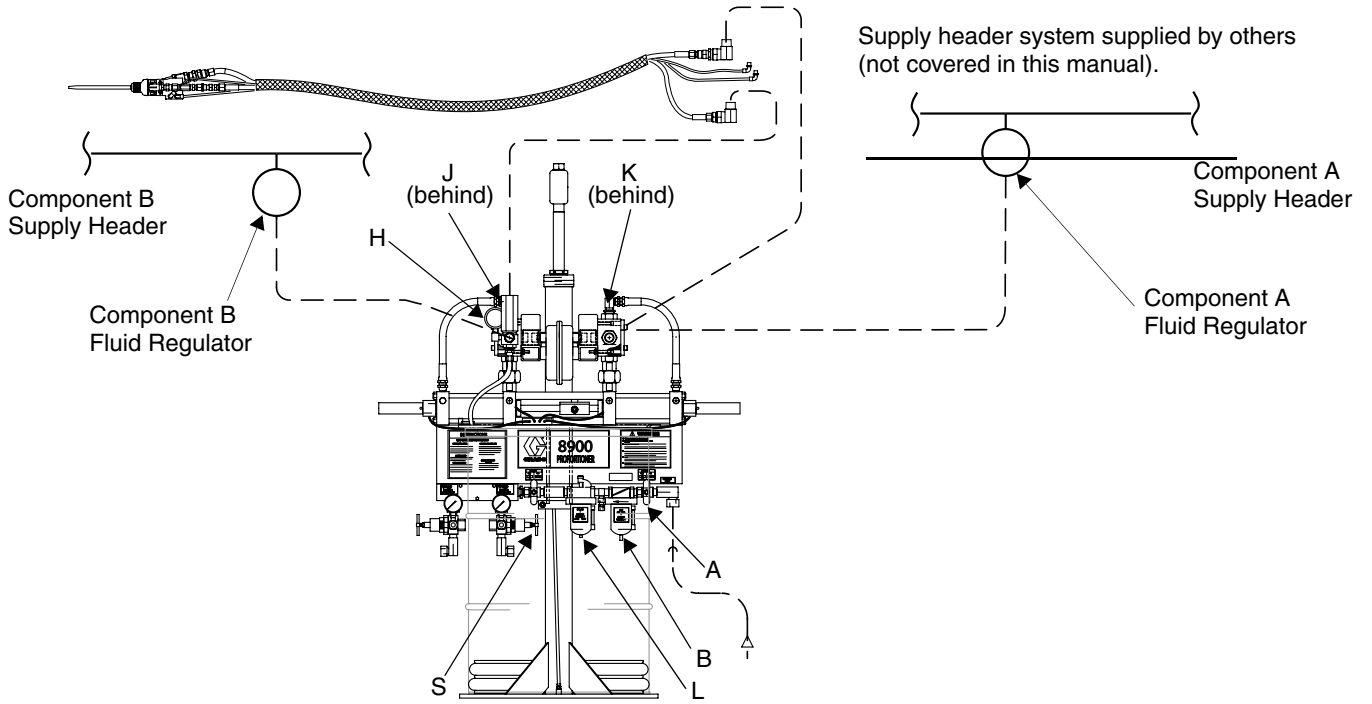

FIG. 1:



ti16759a

FIG. 2:

**Key:FIG. 3**

- |                              |                      |
|------------------------------|----------------------|
| Q 2K Gun                     | X Air Trigger Pilot  |
| V Disposable Mixer Element   | Y Component B Supply |
| W Component B Injector Valve | Z Component A Supply |

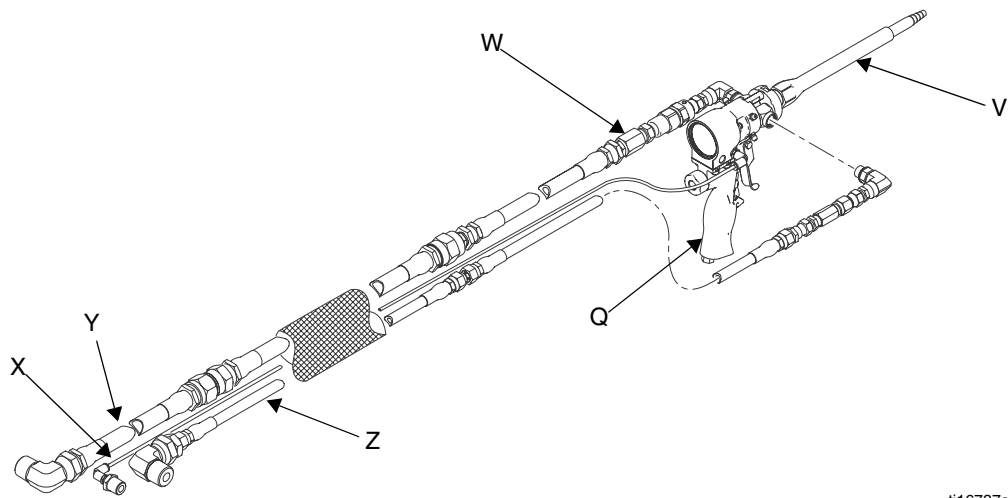

ti16737a

FIG. 3

## Ground

**WARNING**



The system must be properly grounded. Read warnings, page 5. Follow the instructions below.

**Pump:** use the ground wire and clamp (supplied). There are two styles of ground connections on pump air motors.

**If you have the ground screw (a) shown in FIG. 4** (King air motor only), order part no. 222011 ground wire, ring terminal, and clamp assembly (b). To install 222011, remove the ground screw (a) and insert it through the eye of ring terminal (c), then tighten ground screw back into air motor as shown in FIG. 4. Connect the other end of the wire to a true earth ground.

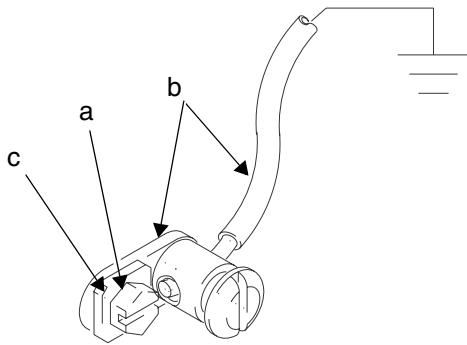

**FIG. 4: Ground Screw (King air motors only)**

**If you have the ground screw (d) shown in FIG. 5,** loosen the grounding lug locknut (g) and washer (f). Insert one end of the ground wire (e) into the slot in lug (d) and tighten the locknut securely. Connect the other end of the wire to a true earth ground. Order 237569 ground wire and clamp assembly.

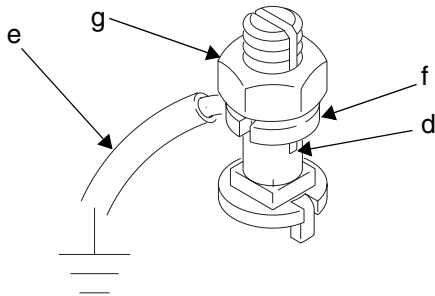

**FIG. 5 Ground Screw**

**Air and fluid hoses:** use only electrically conductive hoses with a maximum of 500 ft (150 m) combined hose length to ensure grounding continuity. Check the electrical resistance of your air and fluid hoses. If the total resistance to ground exceeds 29 megohms, replace the hose immediately.

**Air compressor:** follow manufacturer's recommendations.

**Spray gun/dispense valve:** ground through connection to a properly grounded fluid hose and pump.

**Fluid supply container:** follow your local code.

**Substrate:** follow your local code.

**Solvent pails used when flushing:** follow your local code. Use only conductive, metal pails, placed on a grounded surface. Do not place the pail on a nonconductive surface, such as paper or cardboard, which interrupts grounding continuity.

**To maintain grounding continuity when flushing or relieving pressure:** hold a metal part of the gun/dispense valve firmly to the side of a grounded metal pail, then trigger the gun/valve.

## Flush



### WARNING



Read warnings, pages 4-5. Follow **Ground** instructions, page 12.

- The equipment was tested with light, soluble oil. Flush the system before loading material to avoid contamination.
- Flush at the lowest pressure possible and check connectors for leaks.

To flush the system:

1. On the ram-mounted component A supply units, you must remove the drum ram plate to immerse the A pump in a solvent pail. To remove the plate:
  - a. Disconnect the blow-off air line from the ram plate.
  - b. Disconnect the tie rod nuts from the ram cross beam.
  - c. Remove seal plates between the pump and ram.
  - d. Loosen ram tie rods from plate and remove plate.
  - e. If a pail ram is used with the component B supply, remove the pail plate by loosening the 2 set screws.
  - f. Position the solvent pail so the pump inlet is in the solvent.



Use solvent that is compatible with the equipment wetted parts and the material you will dispense.

- g. Support the ram(s) so that the pump inlet and piston will not hit the base plate or pail bottom.
- h. Make sure both component A and component B outlet hoses are open.

2. Flush the system and all hoses by very slowly opening the motor control valves until 30 psi (207 kPa, 2.1 bar) is shown on the component A outlet pressure gauge.

Flush for 1-2 minutes, then close the motor control valves.



### CAUTION

To avoid damaging the pump, open the motor control valves very slowly to prevent a pump runaway condition.



It is normal for the air valve to exhaust air when it is partially open.

3. Check connectors for leaks and tighten them if necessary.
4. Remove the solvent pail(s) from the pump inlets.
5. Operate the pump(s) at low pressure to remove excess solvent.
6. Reinstall the drum or pail ram plates.

# Setup

**WARNING**



Read warnings, pages 4-5, before operating equipment.

## Set the Ratio (variable ratio models only)

### Adjust ratio

The ratio of this unit is produced partially by the difference in the area of the metering cylinders and partially by the position of the adjustable fulcrum point in the Uni-bar linkage assembly. With the fulcrum point in the center, each meter cylinder strokes 3 in. (10.16 cm). In the center position, the dispense ratio is the same as the meter cylinder ratio.

The linkage is adjustable depending on the location of the fulcrum point. The linkage must be adjusted for each material application so the combined linkage and meter cylinder ratio equals the desired material mix ratio by volume. The ratio may be checked by weight, but the machine meters by volume and that ratio must be known before proceeding.

The initial linkage adjustment point can be calculated by inserting known values into the formula on page 35. The result is the distance in inches from the center of the fulcrum point to the center of the component B meter cylinder. For convenience, measure the distance between the grease fitting on the top of the fulcrum and the center of the component B cylinder meter rod.

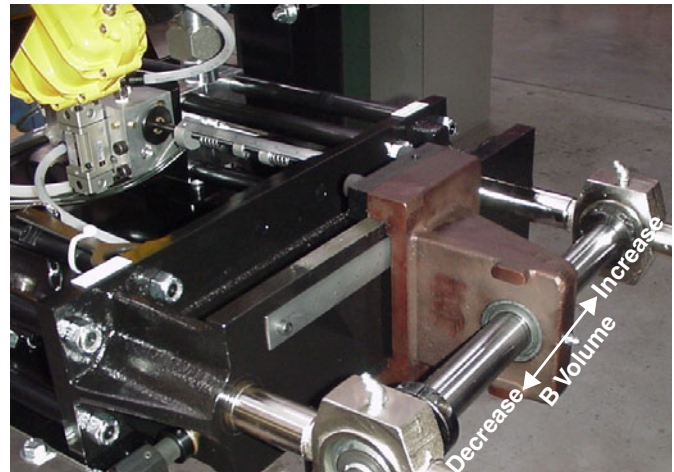

FIG. 6

### Set Scale

Refer to the 8900 Proportioner Output Charts on the following pages to set the scale. Make final adjustments after the material is loaded. See instructions on page 33 for detailed ratio check instructions.

# Output Charts/Ratio Settings

## 8900 Proportioner, 1:1 - 4:1 Variable Ratio

Mix Ratio by Volume	Scale Setting	Minor Stroke
1	5.63	3.00
1.5	7.13	2.00
2	8.13	1.50
2.5	8.85	1.20
3	9.38	1.00
3.5	9.80	0.86
4	10.13	0.75

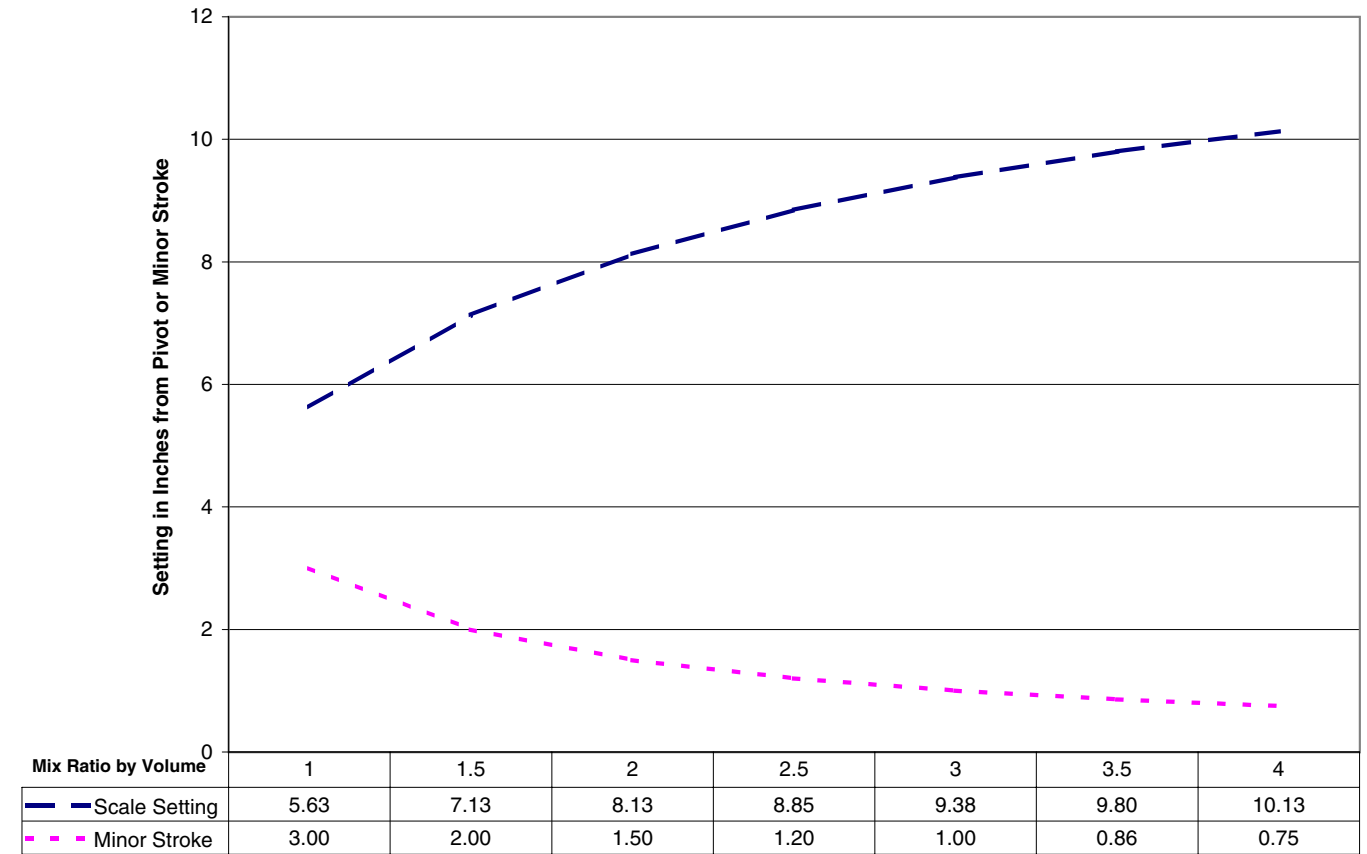

### 8900 Proportioner, 2:1 - 8:1 Variable Ratio

Mix Ratio by Volume	Scale Setting	Minor Stroke
2	5.63	3.00
3	7.13	2.00
4	8.13	1.50
5	8.85	1.20
6	9.38	1.00
7	9.80	0.86
8	10.13	0.75

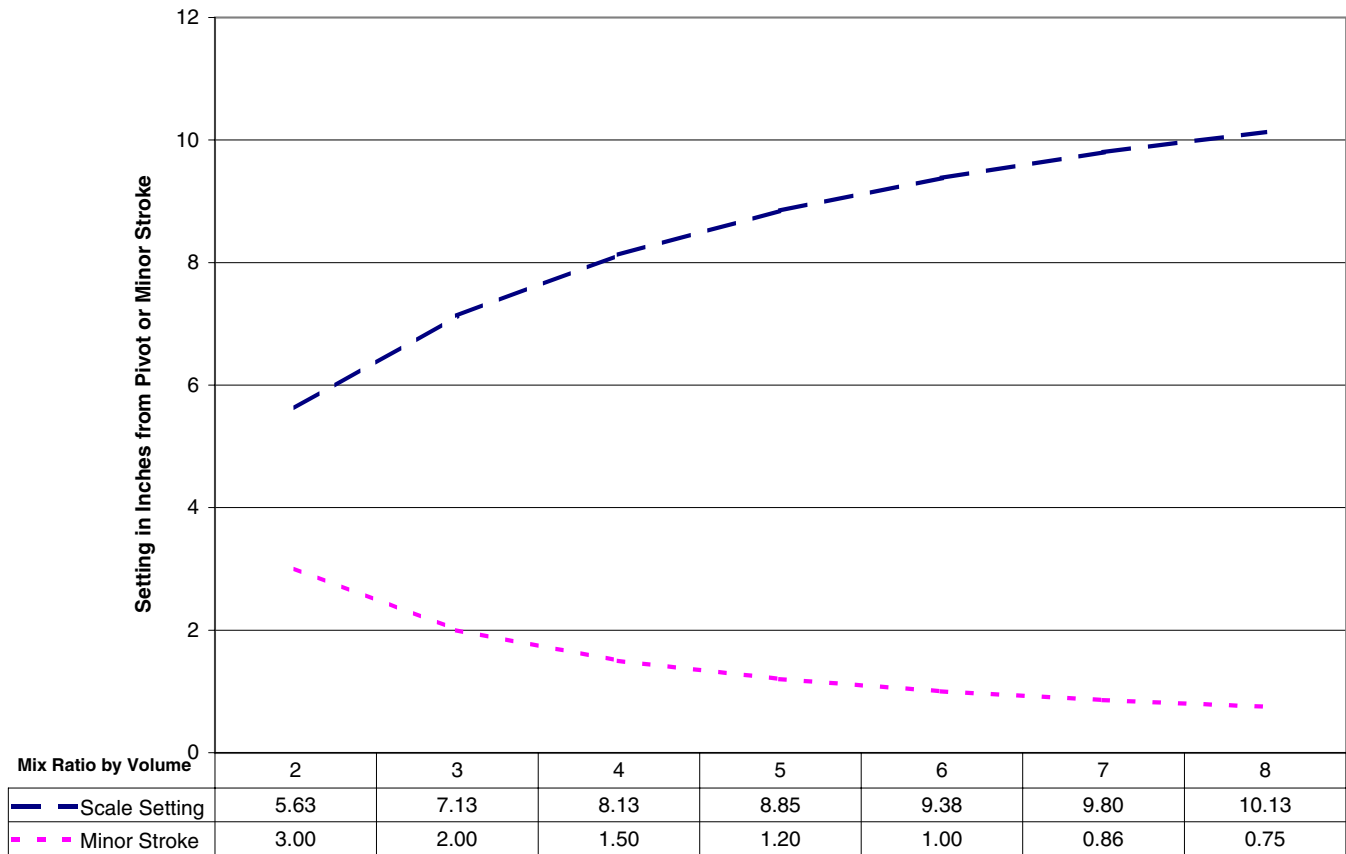

### 8900 Proportioner, 5:1 - 20:1 Variable Ratio

Mix Ratio by Volume	Scale Setting	Minor Stroke
5	5.63	3.00
7	7.13	2.00
10	8.13	1.50
12	8.85	1.20
15	9.38	1.00
17	9.80	0.86
20	10.13	0.75

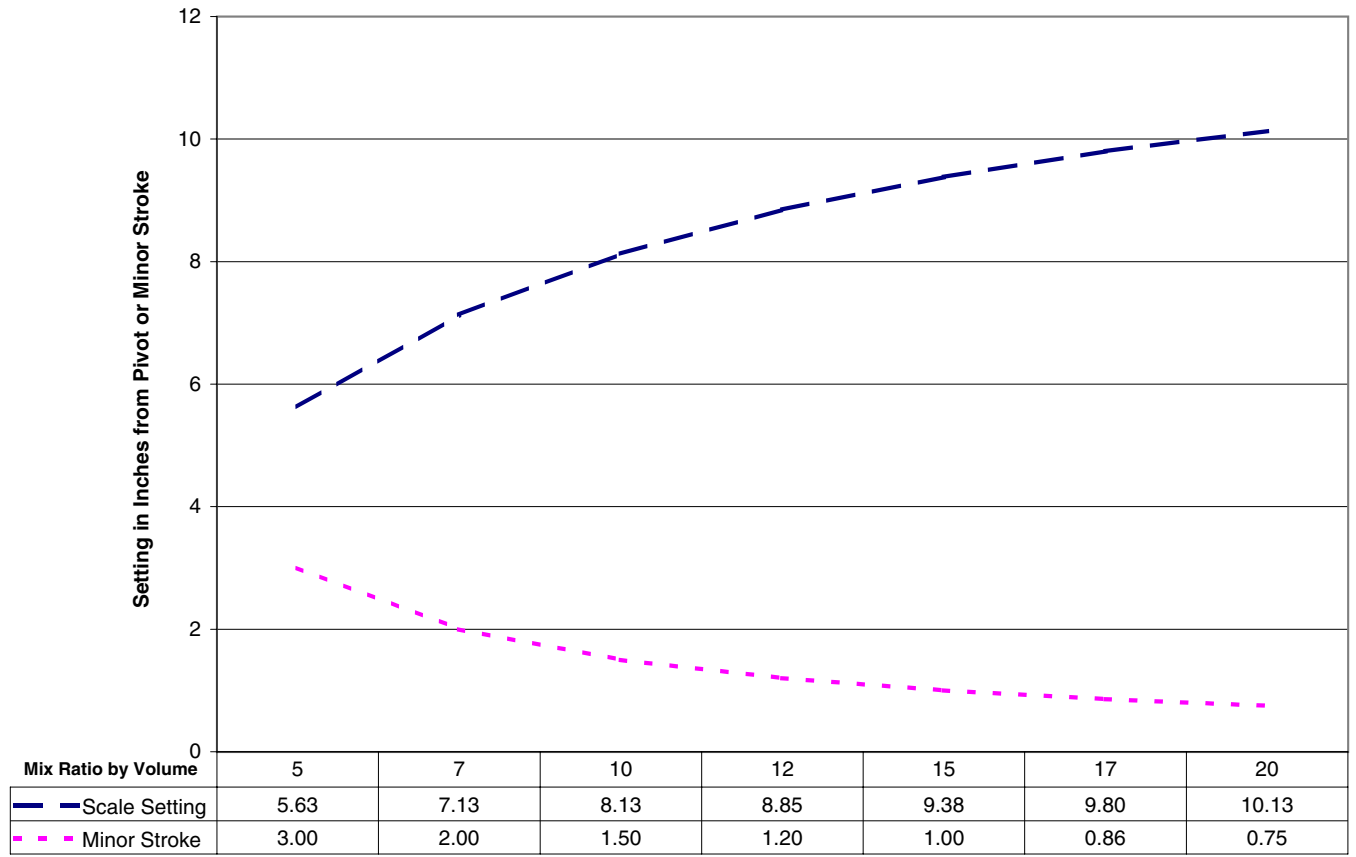

## Before You Load Material

1. Check fluid and air lines and tighten if necessary.
2. Make sure there is a minimum overhead clearance of 110 in. (279 cm) for 55 gallon supply.
3. Fill air line lubricator for the 8900 Proportioner module with SAE 10 W non-detergent oil (not included).
4. Fill the pump A and B wet cups 2/3 full with Graco T.S.L. fluid (throat seal lubricant) or lubricant compatible with material being pumped.

 ISO pump oil is used with moisture sensitive component B.

5. Close (turn fully counterclockwise) all air regulators.
6. Connect the 3/4 in. (19 mm) ID x 10 ft (3.05 m) air hose (provided) to your air supply.

 Do not use a restrictive quick-disconnect. The air supply pressure must be consistently above the pressure you set on the main air motor regulator.

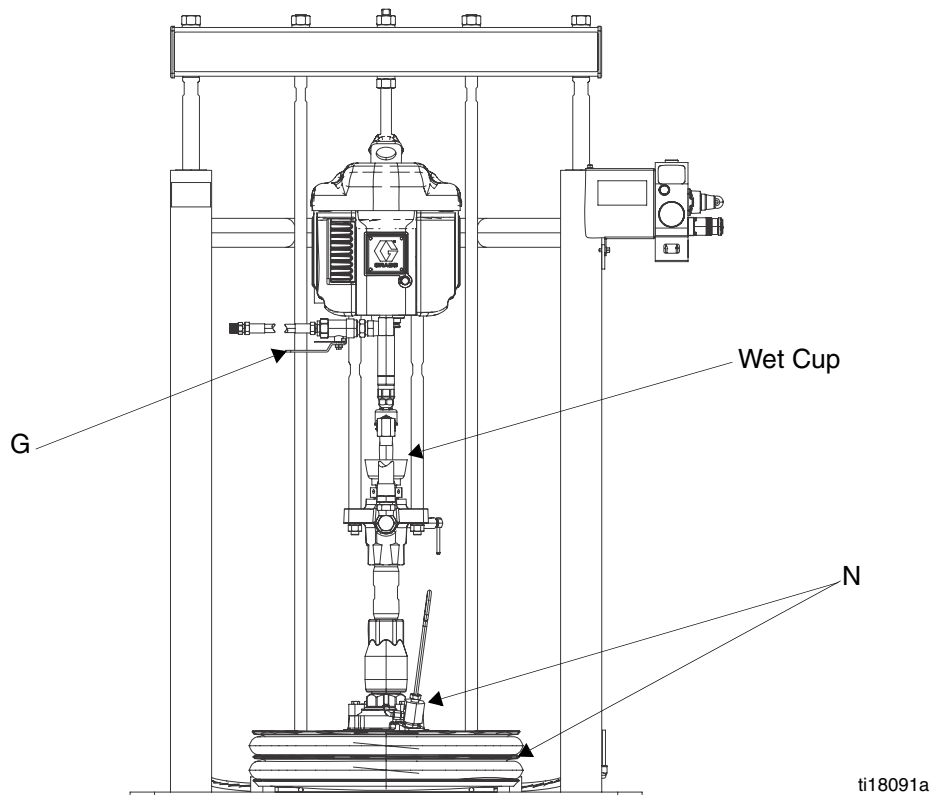

FIG. 7

## Load Component A

1. Make sure all air regulators on proportioner module are fully closed.
2. Open the main air supply shutoff valve (A), FIG. 8.
3. Place the ram lever (P-FIG. 10) in the UP position.

### CAUTION

As the ram rises, make sure hoses do not catch on any components. If a hose catches, immediately stop the ram (move lever to NEUTRAL position) and correct the problem. Lower the ram if necessary to redirect hoses.

4. Slowly turn the ram air regulator (R) clockwise until the ram begins rising.



FIG. 8

5. When ram is fully raised, apply a thin coating of lubricant to the ram plate drum seals.
6. Open the material container. Remove any packing materials, and inspect for material contamination. If the container has a plastic liner, pull it tightly over the sides of the container, and secure the liner in place with tape wrapped below the top drum rim.
7. Position the drum so it rests evenly between the centering guides and is fully backed into the stops located near the back of the ram base plate.
8. Open the drum vent valve (W), FIG. 9.

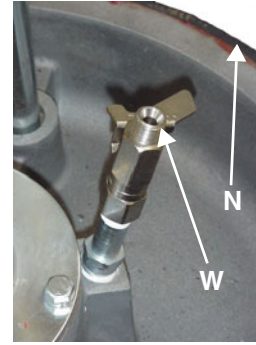

FIG. 9

### WARNING



When lowering the ram, keep hands and body away from the ram plate and material drum. Read warnings, page 5.

9. With hands away from the pail and wiper plate (N), set the ram lever (P-FIG. 10) to NEUTRAL (horizontal position). Let the ram lower until the wiper plate rests on the pail lip.
10. Lower the ram plate into the drum (move ram lever to DOWN position).

### CAUTION

Do not lower ram if a drum is not in place. Doing so can damage drum centering guides.

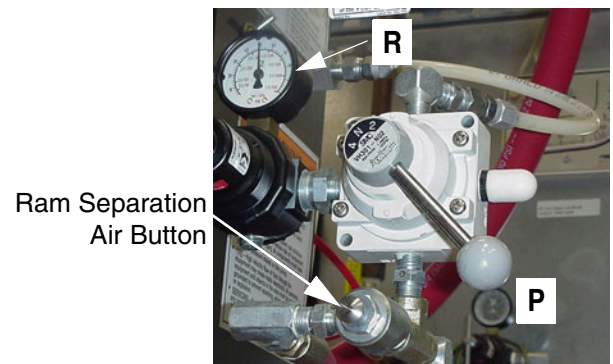

FIG. 10

11. After the ram plate seals contact the drum, adjust the ram air regulator (R) to about 30-50 psi (207-345 kPa, 2.1-3.4 bar).
12. When the ram stops and material fills the bleed port (or air stops bleeding out), close the drum vent valve (W), FIG. 9.
13. Supply unit is now ready to fill lines to proportioner.

## Prime Pump A

1. Place a waste container under the pump bleed valve located behind the displacement pump outlet, FIG. 11. Using an adjustable wrench, open the bleed valve counterclockwise 1/3-1/2 turn.

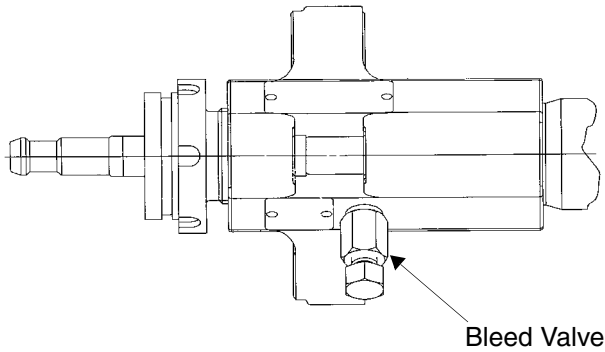



FIG. 11

2. Slowly open the component A air motor shutoff valve (G), FIG. 7. Make sure the pump begins to cycle and material flows from the bleed valve after several cycles of the pump, FIG. 11.

 If the pump does not cycle, close the air shutoff valve (G), adjust the air motor regulator (O-FIG. 8) up 5 psi (34 kPa, 0.3 bar) and repeat step 2. Never adjust the regulator by more than 5 psi (34 kPa, 0.3 bar) increments.

3. Operate the pump until it moves smoothly in both directions with no air popping or erratic movement, then close the air motor shutoff valve (G).
4. Close the bleed valve, FIG. 11.

## Load Component B

Follow the procedure for the type of supply equipment being used.

### Pneumatic Pail Ram and Piston Pump

1. Close all air regulators and air valves.
2. Set the pail ram air regulator (D) to 40 psi (0.28 MPa, 2.8 bar), FIG. 12.
3. Push the ram directional lever (C) to the UP position and let the ram rise to its full height.
4. When ram is fully raised, apply a thin coating of lubricant to the ram plate drum seals.
5. Remove the component B pail cover. If the material has separated, carefully stir it with a metal or plastic rod until it is mixed. Do not use wood to stir as it can splinter and contaminate the material. Do not mix air into the material.
6. Set the pail on the ram base. Slide it back toward the ram tube and supports and center it under the wiper plate. To prevent air from being trapped under the wiper plate, scoop fluid from the center of the pail to the sides to make the surface concave.



#### WARNING



When operating the pump or raising or lowering the ram, keep hands away from the wiper plate, fluid container lip, and pump intake. Read warnings, page 5.

7. With hands away from the pail and wiper plate, set the ram lever (C) to NEUTRAL (horizontal position). Let the ram lower until the wiper plate rests on the pail lip.
8. Ensure the pail is aligned with the wiper plate.
9. Push the ram directional lever (C) DOWN and increase ram air pressure until plate completely engages into the pail.
10. Slowly unscrew the vent stick until you hear air escaping. When air is evacuated, set the ram lever (C) to NEUTRAL and lower ram pressure to 20-30 psi (138-207 kPa, 1.4-2.1 bar).
11. Unscrew the vent stick and put the ram lever (M) in the DOWN position, keeping the vent stick over the vent port.
12. Slowly increase down pressure until material seeps from vent port, the quickly refasten vent stick.

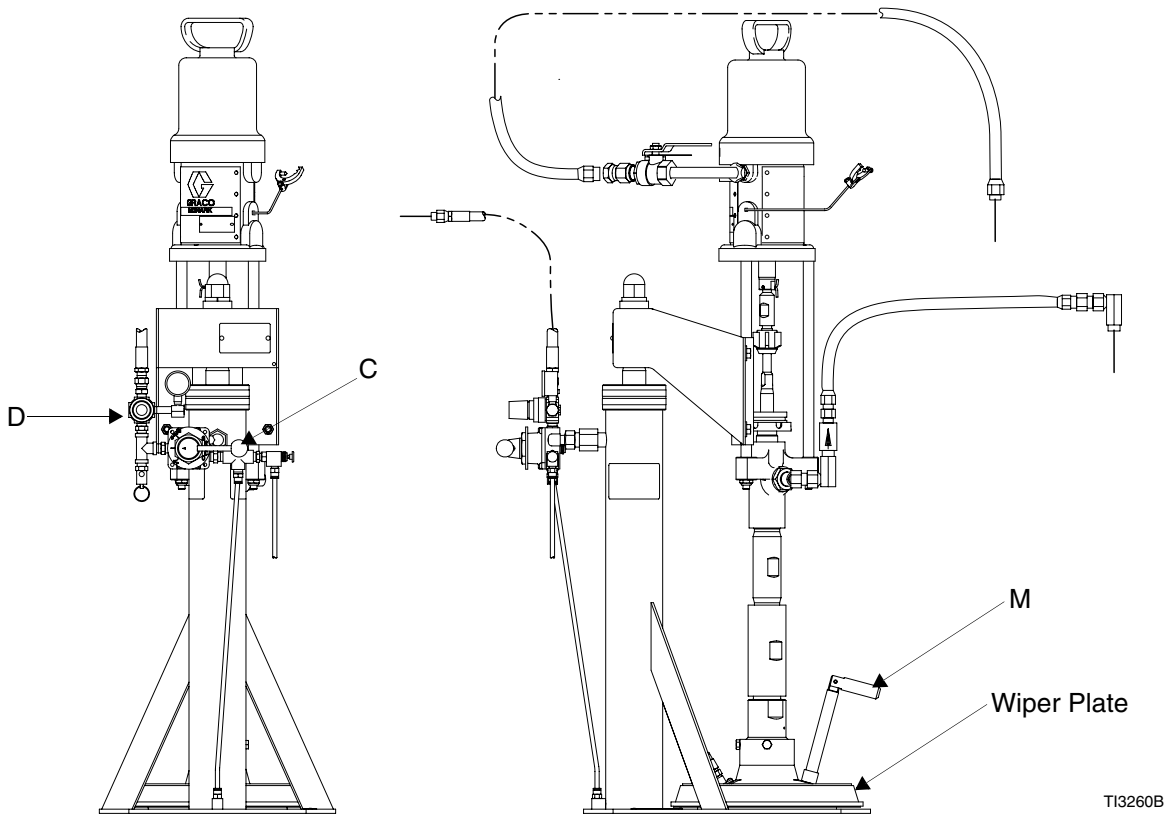

TI3260B

FIG. 12

## Pressure Tank with 15:1 Booster

1. Relieve tank pressure before opening.
2. Remove the pressure tank lid and any items shipped inside the tank. Make sure the tank is clean, or use the liner supplied.
3. Be sure the desiccant air dryer is mounted in the component B tank air supply of the proportioner air control module. See FIG. 28, page 32.
4. Gently roll an unopened pail of component B on the floor for several revolutions to mix it.
5. Open the pail outlet and carefully pour component B into the tank.
6. Immediately close the tank by tightening the T-handles (GG) evenly, FIG. 13.

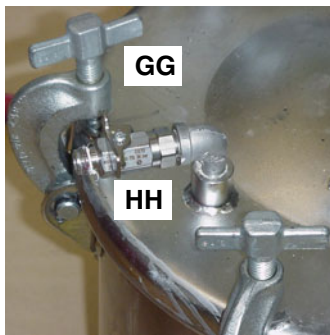

FIG. 13

7. Pressurize the tank with dried air by opening the component B air shutoff valve (S) and the pressure tank air shutoff valve (T), FIGures 14 and 15.

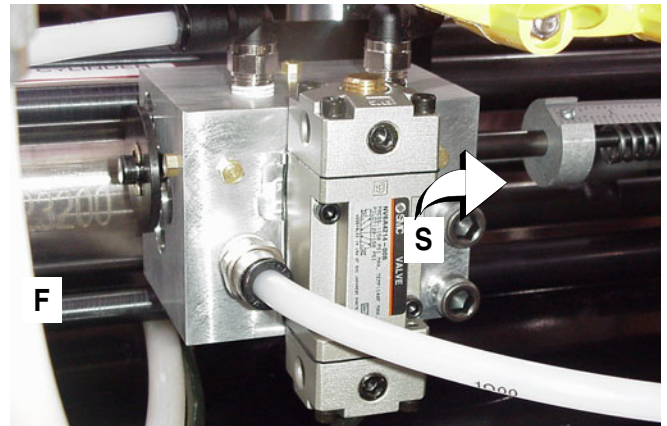
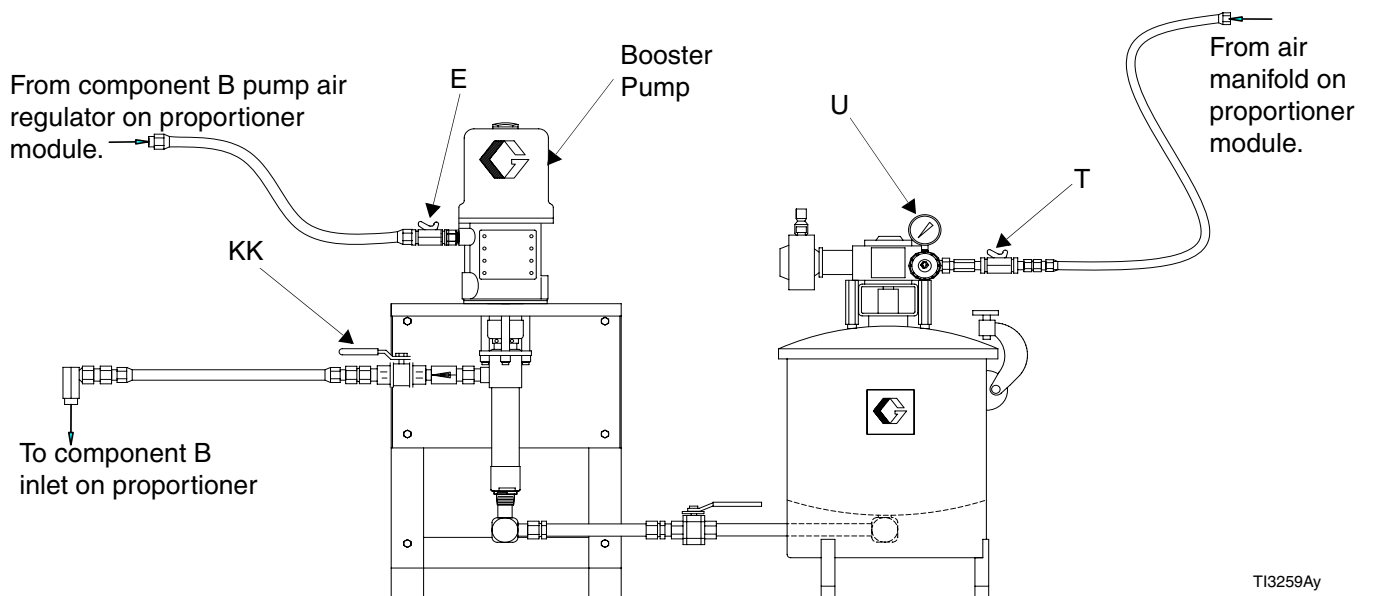

FIG. 14

8. Set the component B tank air regulator (U) to approximately 40 psi (276 kPa, 2.8 bar).
9. Check to ensure the air valve (E) to booster pump is turned off and material supply ball valve (KK) is closed.
10. Set feed pump regulator (F) on proportioner assembly to approximately 40 psi (276 kPa, 2.8 bar).
11. The unit is ready to feed material to proportioner.



T13259Ay

FIG. 15

## Prime with Component B

1. Place a waste container under the pump bleed valve located behind the displacement pump outlet, FIG. 16. Using an adjustable wrench, open the bleed valve counterclockwise 1/3-1/2 turn.

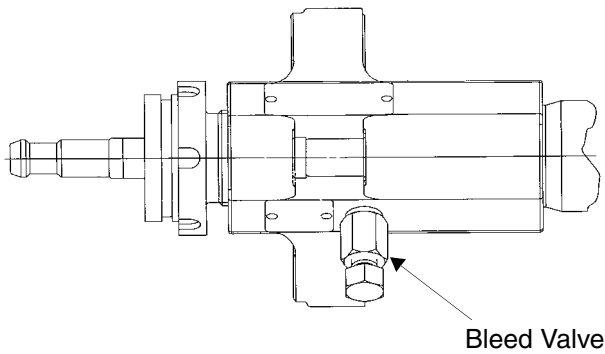



FIG. 16

2. Slowly open the component B air motor shutoff valve (E), FIG. 15. Make sure the pump begins to cycle and material flows from the bleed valve after several cycles of the pump, FIG. 16.

 If the pump does not cycle, close the air shutoff valve (E), adjust the air motor regulator (F-FIG. 17) up 5 psi (34 kPa, 0.3 bar) and repeat step 2. Never adjust the regulator by more than 5 psi (34 kPa, 0.3 bar) increments.

3. Operate the pump until it moves smoothly in both directions with no air popping or erratic movement, then close the air motor shutoff valve (E), FIG. 15.
4. Close the bleed valve, FIG. 16.

## Fill the 8900 Proportioner with Material

1. Place a material waste container under dispense gun (Q) and open gun. FIG. 1, page 10.
2. Open the main ball valve (A-FIG. 17) on the proportioner assembly. This air valve supplies air to the proportioner control valving and to the feed pump assemblies. All other air shut-off valves on the manifold and feed pump assemblies should be off.
3. Open the feed pump main air valve (S). This allows the air supply to feed pump assemblies.
4. Adjust the component B supply pump air regulator (F) to allow smooth pumping action. Continue until component B flows from the dispense gun into the waste container.

 The minor or component B side of material is filled first to minimize waste during initial startup.

5. Adjust the component A air regulator (O) to allow smooth pumping action.
6. Pump until component A and component B flow from the gun into the waste container. When the material is bubble-free, all air has been purged from the system.
7. Turn off air supply valve (S).
8. Close dispense gun.
9. The 8900 Proportioner is now filled with components A and B and ready for operation.

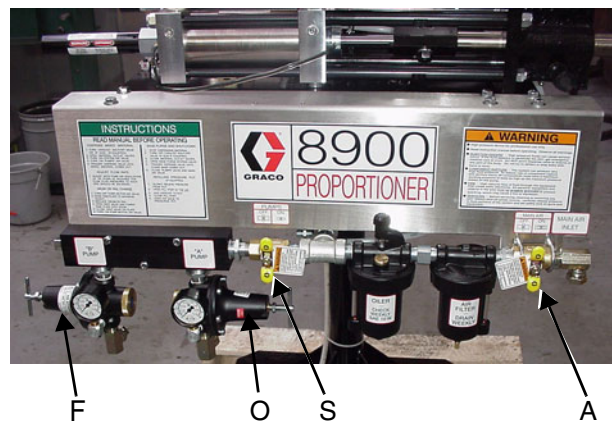

FIG. 17

## MD2 Disposable Mixer Gun Models

Follow steps 10-12.

10. Fit the hose to the gun. Trigger the gun into a waste container.
11. Open the component B feed air shutoff valve (E-FIG. 15). Component B will feed through the metering cylinder to the mix gun.
12. When bubble free material is dispensed, stop triggering the gun.

## All Models



The system is now ready to dispense mixed material.



### CAUTION



The materials will cure after mixing. Purge the mixer, hose, and gun with clean material before the material begins to cure.



# Operation

## Pressure Relief Procedure

**⚠ WARNING**

Read warnings, page 4, and follow the **Pressure Relief Procedure** whenever you:

- are instructed to relieve pressure
- stop dispensing
- check or service any of the equipment
- install or clean the nozzle.

1. Purge mixed material if necessary. See page 29.
2. Close the main air shutoff valve (A), FIG. 18.



FIG. 18

3. If a component B pressure tank is used, open its vent (refer to page 23).
4. Hold a metal part of the gun firmly to the side of a grounded metal pail, and trigger the gun to relieve pressure.
5. For both component A and component B, open the respective pump bleed valves, having a waste container ready to catch the drainage, FIG. 19.

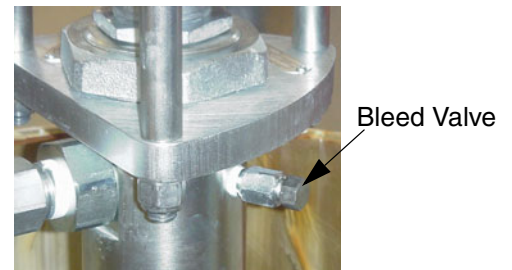

FIG. 19

6. Manually activate the limit valve (item 26 on page 48), to cause the 4-way valve to shift, fully relieving pressure within the proportioner.
7. *If you suspect that the nozzle or hose is completely clogged, or that pressure has not been fully relieved after following the steps above, very slowly loosen the tip retaining nut or hose end coupling and relieve pressure gradually, then loosen it completely, and clear the nozzle or hose.*

## Dispense Mixed Material

### CAUTION

Make sure the component B relief valve is operational and free from blockage at all times. See manual 308547. If the relief valve fails, the overpressure rupture disc opens and component B is diverted to a waste container mounted on the ram base plate.

### 8900 Proportioner with Static Mix Chamber Kits

1. Load the material. See page 19.
2. On the variable ratio machine, set ratio (see page 14). On the fixed ratio machine, proceed to step 3.
3. Open the pump A and pump B air shutoff valve (S), FIG. 20.

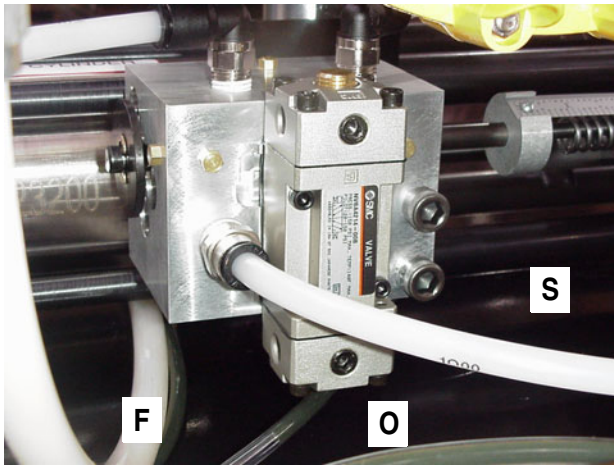

FIG. 20

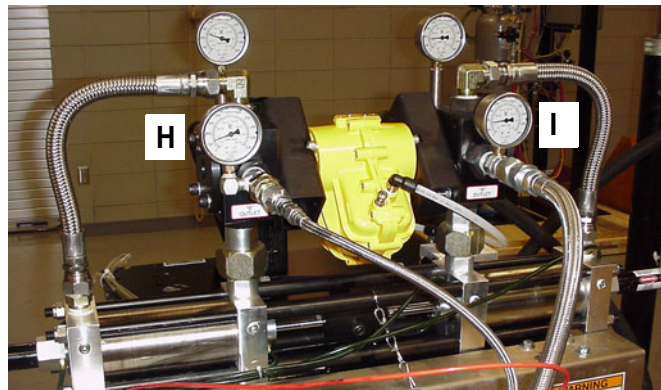

FIG. 21

4. Adjust the component A and component B air regulators (F and O) until both outbound gauges (H and I) show the desired pressure, FIG. 20-21.
5. Trigger the gun to dispense mixed material.

### Adjust the Flow Rate

The dispensing flow rate for the system is controlled by the material pressure of component A and component B. The air pressure on pump A determines the flow rate from the material outlet. Perform the steps on page page 24 to set an initial flow rate. When the setup is complete, adjust flow to the correct rate.

The diagram in FIG. 22 shows the inlet and outlet of the meter cylinders in relation to the direction of rod movement. The material pressure gauges will represent either inlet or outlet pressure, depending on the direction of the rod. Inlet and outlet pressures are critical to establishing meter flow rates and balanced pressures.

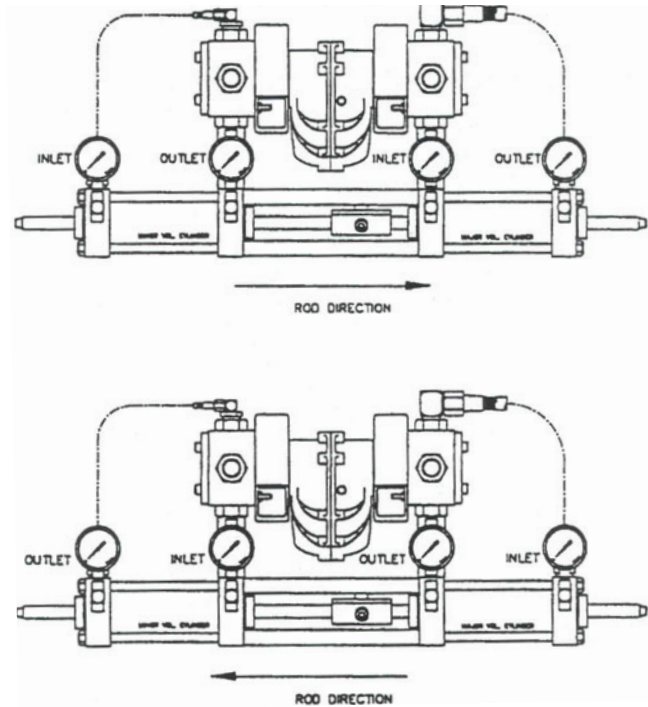

FIG. 22

### Flow Rate Adjustment Example

A 20:1 fluid:air supply pump ratio with an air regulator setting at 100 psi (.7 MPa, 7 bar). The pump generates approximately 2000 psi (14 MPa, 140 bar). Fluid pressure, normal friction losses with mastic materials will use 5-15% of the force, resulting in actual stall pressure of 1700-1900 psi (13 MPa, 130 bar).

### A/B Pump Relationship

As a rule of thumb, the pressures of the two components should be adjusted to as close to equal as possible under dynamic pressure. Adjust the A and B feed pressures to accomplish this. Differences on material viscosity, flow rates, hose diameter and length, dispense valve, and mixer size cause this setting to vary from application to application.

1. Adjust the component A air regulator (O) for desired flow rate, FIG. 24.
2. Adjust the component B air regulator (F) to balance the A and B regulators.

### Solvent-flush Mixed Material (for units using mix manifold gun kits)

1. Close the component A and component B valves on the mix chamber assembly. See FIG. 23.
2. Ensure solvent valve is closed.
3. Set solvent flush pump air regulator to approximately 25 psi (172 kPa, 1.7 bar) and open the air valve.
4. Open the solvent supply valve, ensuring that the dispense valve touches a grounded metal waste container and purge until solvent comes out clean.
5. Close solvent supply valve.

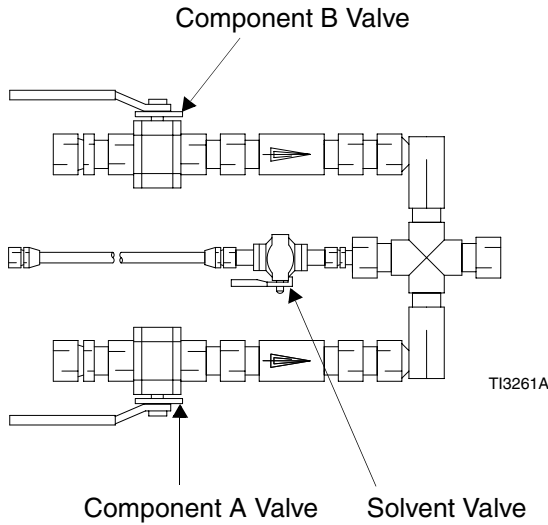

FIG. 23

### 8900 Proportioner with Disposable Mixer Gun

1. Load the material. See page 19.
2. Set ratio. (For variable ratio models, see page 14).
3. Install the mixer on the gun.
4. Open the pump A and pump B air shutoff valve (S), FIG. 24.

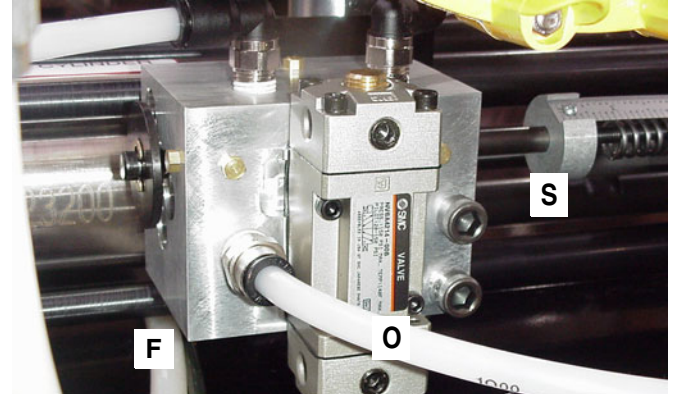

FIG. 24

5. Trigger the gun to dispense mixed material.
6. Adjust the component A air regulator (O) for the desired flow rate.
7. Adjust the component B supply air regulator (F) so that component B pressure is approximately equal to the component A pressure.
8. When you have finished dispensing, remove and dispose of the mixer, and install a red plastic cap (part no. 551327).

## Changing Component A Drum

When the ram plate is extended fully to the bottom of the drum and the pump begins to cavitate, you need to change the drum. It is recommended that you check and refill the component B at the same time.

1. Close the air motor shutoff valve.
2. With the ram lever (PP) in the neutral position (FIG. 25), adjust the ram regulator (R-FIG. 26) to 0 psi.

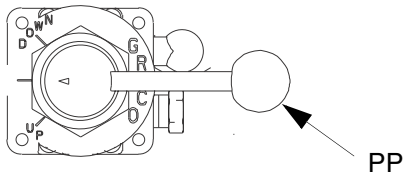

FIG. 25

3. Place the ram lever (PP) in the UP position, FIG. 26.

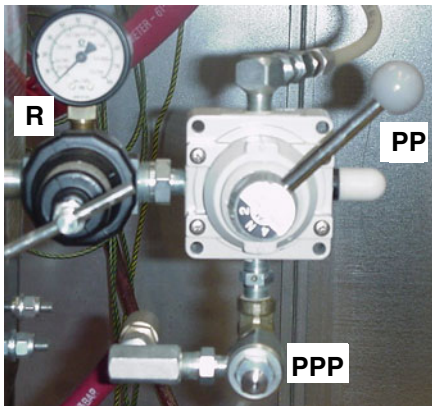



FIG. 26

**WARNING**



Do not use excessive drum separation air pressure. Make sure the drum is not damaged and the ram plate is free to exit the drum. Read warnings, page 5.

4. Push and hold the ram separation air button (PPP).
5. Adjust the ram regulator (R) to approximately 10-15 psi (69-103 kPa, 0.7-1 bar) or until the ram plate begins to rise.

6. Continue to hold the drum separation air button (PPP) just enough to keep the drum from rising with the ram plate.
7. Follow the procedure to load material, pages 19-24.



You only need to lubricate the ram plate tire seals the first time you load material.

## Changing Component B Pail

If you are using a ram and pump to supply component B, the procedure to change the pail is the same as changing the Component A drum except that you use the controls on the back of the pail ram.

### Pressure Relief Procedure

(For component B tank models only.)

**⚠ WARNING**



**PRESSURIZED EQUIPMENT HAZARD**

The pressure tanks remain pressurized until pressure is manually relieved. To reduce the risk of serious injury from pressurized fluid or accidental spray from the gun, always follow this procedure to relieve pressure in the tank at the following times:

- Before you check or service any part of the spray system
- Before you loosen or remove the pressure tank cover or fill port.
- Whenever you stop spraying.

1. Shut off the air supply to the tank by closing the air inlet valve. Refer to FIG. 27.
2. Open the drain cock fitting by turning it counter-clockwise.
3. Wait until there is no air escaping through the drain cock fitting before removing the cover or opening the fill port.
4. Leave the drain cock fitting open until you have reinstalled the cover or fill port.

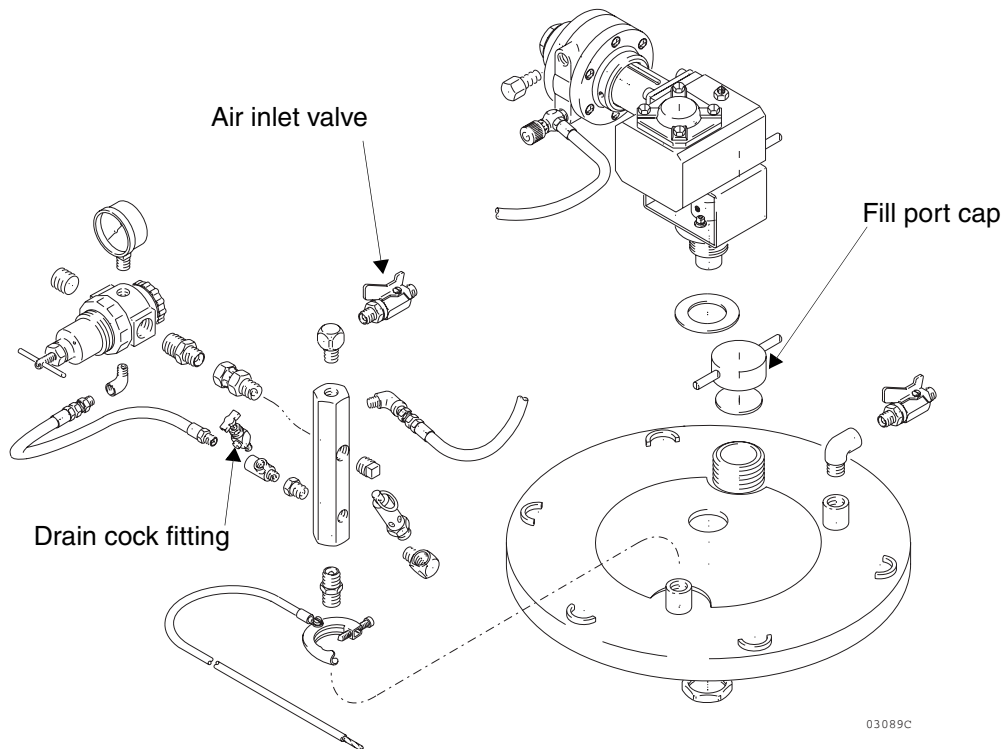

FIG. 27

## Filling Component B Pressure Tank

If you are using a pressure tank to supply component B, check the tank level with a metal or plastic rod whenever the Component A drum is changed. To add component B to the tank, follow the procedure below.

1. Close the tank air supply shutoff valve, FIG. 28.
2. Relieve pressure in the tank (see page 27).
3. Open the fill port cap on top of cover.

**⚠ CAUTION**  
Do not leave the pressure tank open. Component B will crystallize if exposed to the moisture in the air. The tank cover is normally removed only for tank cleaning.

4. Gently roll an unopened pail of component B on the floor for several revolutions to mix it.
5. Open the pail outlet and carefully pour the material into the tank through a funnel.
6. Close the drain cock fitting and screw on the cap.
7. Make sure the silica-gel in the desiccant filter is blue. If the gel is pink, replace it (part no. 106498) or bake out the moisture.

 The desiccant filter is an air dryer for moisture-sensitive materials, it is not included with the package.

8. Pressurize the tank with dried air by opening the component B air shutoff valve and the pressure tank air shutoff valve.

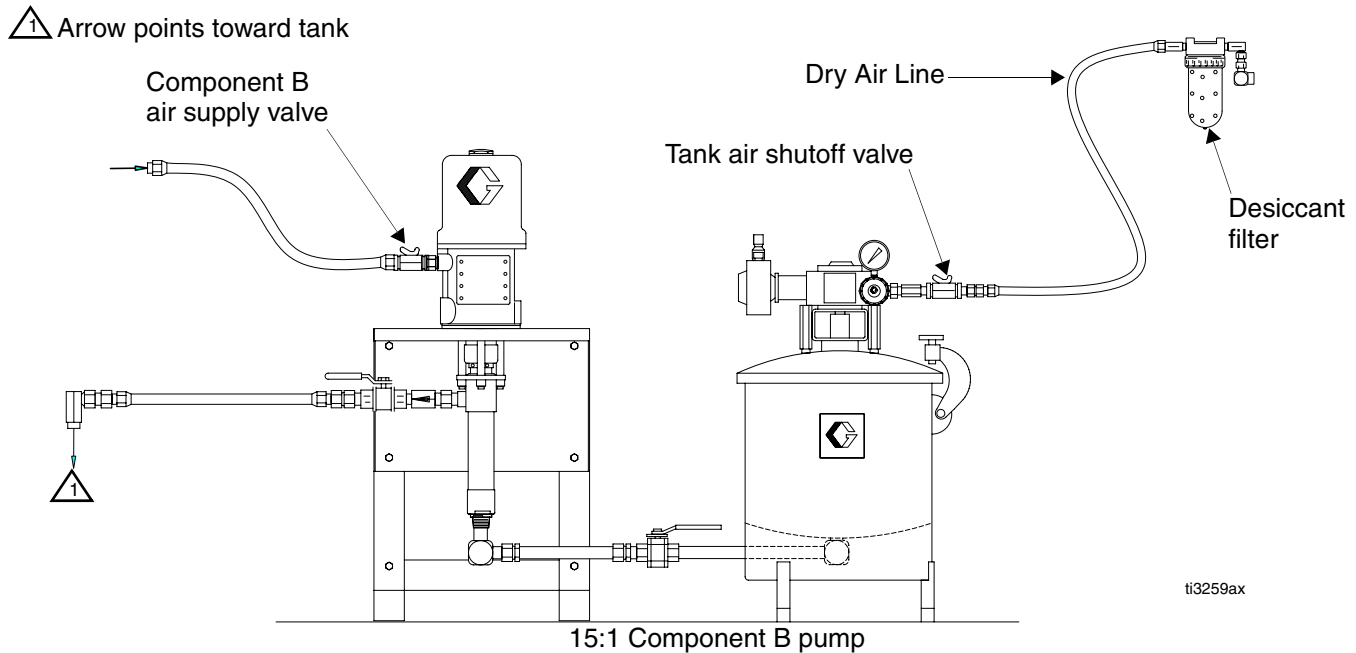

FIG. 28

### Adjust Ratio on Variable Ratio Machine

The ratio of this unit is determined partially by the difference in the area of the metering cylinders and partially by the position of the adjustable fulcrum point in the Uni-bar linkage assembly. With the fulcrum in the center, (next to stop at left of center), each meter cylinder strokes 3 in. In this center position, the dispense ratio is the same as the meter cylinder ratio. The ratio is adjustable from 1:1 to 20:1 depending on the location of the fulcrum point and cylinder size. There are three machines to accommodate these ratio ranges: 1:1-4:1, 2:1-8:1, and 5:1 to 20:1. The linkage must be adjusted for each material application so that the combination linkage and meter cylinder ratio equals the desired material mix ratio by volume. The ratio is checked by weight, but the machine meters by volume. Weight ratios must be known before proceeding. If weight ratios are not known, they can be calculated using the specific gravity and known volumetric ratio of each component.

The initial linkage adjustment point can be calculated by inserting known values into the following formula. The resulting value is the distance in inches from the center of the fulcrum point to the center of the component B meter cylinder. Measure the distance from the grease fitting on top of the fulcrum to the center of the component B cylinder meter rod. For reference, see the output charts on pages 15 through 17.

#### Ratio Adjustment Calculation Example:

**DR** = Required mix ratio by desired volume (X:1)

**PR** = Selected cylinder ratio (1:1, 2:1, 5:1)

**LR** = Linkage ratio

**LD** = Linkage distance (component B cylinder centerline to fulcrum center divided by LR+1)

$$\frac{DR}{PR} = LR$$

Cylinder ratio 1:1-4:1 machine use **PR** = 1

Cylinder ratio 2:1-8:1 machine use **PR** = 2

Cylinder ratio 5:1-20:1 machine use **PR** = 5)

#### Example:

- Desired volumetric mix ratio (**DR**) = **10:1**
- Measured distance from grease fitting on top of the fulcrum to the center of the component B cylinder meter rod = **14.85 in.**

$$\frac{DR}{PR} = LR \quad \frac{10}{5} = 2:1$$

$$LD = \frac{\text{measured distance}}{LR + 1} \quad LD = \frac{14.85 \text{ in.}}{2 + 1} \text{ or } LD = 4.95 \text{ in.}$$

### Verify the Ratio

1. Relieve pressure. See **Pressure Relief Procedure** on page 27.
2. Remove gun and place a waste container under the component A and component B hoses.
3. Open air valve to turn on unit.
4. Activate the unit and using a collection container of known weight, collect a cup of component A and a proportionate amount of component B.
5. Weigh each component carefully and subtract the weight of the container.
6. Convert the manufacturer's ratio to parts component B per 100 parts Component A, by weight (2:1 = 100:50).
7. Divide component B weight by component A weight.
8. Multiply the result of step 7 by 100. The product is the number of parts of component B the machine dispenses per 100 parts of Component A.
9. Compare ratio obtained to ratio desired. Always make several ratio checks to ensure accuracy at final setup. Any air in the system will cause inaccurate ratio checks. If ratio checks are not consistent, review setup procedure.
10. If the ratio is incorrect, loosen fulcrum screw (A) and turn the ratio adjustment screw/nut (B) clockwise to decrease and counterclockwise to increase the amount of component B.
11. If the ratio is correct, tighten the fulcrum nut and reattach hoses (7) to the dispensing gun.

## Daily Procedures

### Daily Start-up Procedure

1. Perform daily maintenance operations, including:
  - a. Check oil level in main air lubricator.
  - b. Drain any water from filter in main air line.
  - c. Tighten pump packing nuts (daily the first week, weekly thereafter).
  - d. Visually inspect system for leaks.
  - e. Grease zerk fittings.
2. Turn air pressure to the unit "ON".
3. Check ratio on variable ratio models.

 Steps 4 and 5 are applicable only to mix manifold models.

4. Open the coupled ball valves (push up).
5. Ensure that the component A purge ball valve is closed.
6. Place a material waste container under the gun outlet and open the dispense gun.
7. Dispense material until well mixed material is being dispensed.
8. The system is now ready to operate.

### Daily Shut-down/Purge Procedures

#### Component A Purge

1. Close the coupled ball valves (push down).
2. Open the component A purge ball valve.
3. Hold the dispense gun over a material waste container.
4. Hold the dispense gun open until only component A is evident.
5. Close the component A purge ball valve.
6. Close the main air valve located under the meter base plate to remove air pressure from the meter.

 After the system is purged, do not open the dispense gun until the next system operation.

### Disposable Mixer System

1. Remove and discard the mixer.
2. Trigger gun to ensure the outlet is clear.
3. Turn off the main air valve.
4. Wiper off gun nose.
5. If material is moisture-sensitive or dries out, protect the outlet with the night cap and ISO pump oil.

### General Ratio Check Procedure

Checking the ratio allows the user to take samples of the metered material to ensure the equipment is operating properly.

 The unit meters by volume but it is more convenient to check the ratio by weight. You must know the ratio by weight or the specific gravity of the materials to convert volumetric ratio to weight ratio.

1. Remove the hoses from the dispense gun. Take a material sample from the outlet of these hoses.
2. Open the air ball valves (push up) and collect a large material sample (approximately 1 pint of component A) in separate containers of known weight. Material flowing from each hose provides a sample for ratio check. When sample is collected, turn off air supply ball valve.
3. Weigh the component A and component B samples and subtract the weight of the collection containers.
4. Convert the material manufacturer's ratio to "parts component B per 100 parts component A by weight." For example, a 2:1 ratio (component A: component B) becomes 100:50.
5. Divide component B sample weight by component A sample weight.
6. Multiply the result of previous step by 100. The product is the parts component B dispensed by the machine per 100 parts component A by weight.
7. Compare the weight ratio obtained to the desired weight ratio. Repeat to obtain several successful ratio checks.
8. Put new mix elements in the gun and reconnect the hoses to the gun.

9. Ration check is complete and the unit is ready for operation

**Ratio Check Example**

**Conversion Formula:**

**Parts by Volume (PBV) to Parts by Weight (PBW)**

$$\frac{\text{PBV component B}}{\text{PBV component A}} \times \frac{\text{Specific gravity component B}}{\text{Specific gravity component A}} \times 100 = \mathbf{X}$$

$\mathbf{X}$  = 100:Parts component B by weight

**Ratio Check Example**

$$\frac{\text{component B sample weight LESS container weight}}{\text{component A sample weight LESS container weight}} \times 100 = \text{PRODUCT}$$

PRODUCT = Parts component B per 100 parts component A

- Manufacture’s specified weight ratio = 4:1 or 100:25.
- Weight of component A in ratio check is 245 grams.
- Weight of component B in ratio check is 61.2 grams.
- 61.2 divided by 245 equals .2497 (61.2 / 245 = .2497).

Three ratio checks are recommended to ensure accuracy at final setup. The presence of any air (visible or not visible) in the material or system will cause inaccurate ratio checks. If the ratio check cannot be made with repetitive accuracy, review air bleed procedures.



Some materials contain substantial amounts of entrained air due to manufacturing, transportation, system setup, or drum change. Air must be removed by de-gassing, recirculation, or self removal over time, before accurate metering can be accomplished.

# Troubleshooting

## 8900 Proportioner Operating Pressures

There are four fluid pressure gauges on a typical 8900 Proportioner system. They are mounted on:

- Component A inlet block
- Component B inlet block
- Component A outlet block
- Component B outlet block

### What the fluid gauges tell you

#### Inlet Gauge

The pump A and pump B inlet pressure gauge shows whether there is sufficient material supply to reliably feed each metering pump during its intake stroke. These double-acting pumps dispense and load fluid on both strokes.

The pump A and pump B supply air pressure should be set high enough to maintain reliable pump feed pressures but no higher than necessary. If gauge pressure is not consistently steady, increase fluid pressure.

#### Outlet Gauge

The pump A and pump B outlet gauge displays one of two conditions, *stalled* and *running*.

- **Stalled:** With the pump air valve on and the gun closed, the gauge will show full stall pressure. This pressure is the fluid to air pressure ratio of the pump assembly, times the air pressure from the main regulator, minus the friction loss of the motor and pump assembly.

The fluid to air pressure ratio changes with different motors, different supply pumps, and different ratio settings.

- **Running:** When running, the gauge reads the flow-induced pressure drop between the gauge and the gun outlet. The motor power is used up by the time the fluid exits the gun. The pressure drop is a measure of friction loss caused by hoses, the 8900 Proportioner, fittings, mixers, and gun.

The difference in the gauge reading between the stall condition and running is the amount of dynamic friction loss from the pump assembly, plus the flow-induced pressure drop from the pump lower to the pressure gauge.

Viscosity, temperature, flow rate, and gun setup can affect the amount of gauge drop when the trigger is pulled. On a typical manual gun system, the gauge drops 100-400 psi (0.7-2.8 MPa, 7-28 bar).

#### Component B Pump Outlet Gauge

The component B pump gauge shows line pressure, but the component B outlet pressure is generated primarily as a reaction to component A pressure at the mix chamber.

For materials running at greater than 1:1 ratio, component B cannot open the check (injector) valve until its pressure equals the component A pressure at the check valve. Hoses and injector restriction are chosen to naturally balance the pressure drop while running and match the component B pressure in the line when stalled.

#### Changeovers

When the pumps change direction there is a momentary change in gauges. In general, the gauges will drop 5-15%, then return. However, many factors affect the actual fluctuation, such as pump selection, fluid characteristics, flow rate, temperature, and length of hoses.

Check valves near the pump outlets isolate the hoses to let them serve as momentary surge chambers. This is why flow from the gun is smooth during changeover.

#### Abnormal Readings

Since so many factors affect gauge readings, it is important to know what is normal. Note how your gauges read when the machine is setup and running a good mix with no soft spots. What are the stall pressures and what are the running pressures for a given inbound air pressure? How much drop is there on changeover?

If something goes wrong, a change on the gauges can indicate what the problem is. Note those changes and work through the troubleshooting guide, beginning on page 39.

## Air Supply Troubleshooting Chart

Problem	Cause	Solution
Abnormal pressure loss on air motor pressure regulator gauge during both changeovers.	Air line restriction due to quick-disconnect pin fitting.	Remove quick-disconnect from the air line and replace it with bleed-type air shutoff valve.
Abnormal A and B pump outlet pressure loss during both changeovers.	Air supply line ID to each feed pump is too small.	Replace with minimum 3/4 in. (19 mm) ID hose.
Reduced flow rate.	Undersized air compressor.	Replace with properly sized air compressor.
Off-ratio material.		

During normal operating conditions, the feed pump (A and B) air motors are filled with air almost instantaneously on both changeovers.

However, if the feed pump air supply is restricted, it can take significantly longer for air to fill the air motor. To check for this, observe the gauge on the air motor pressure regulator during both changeovers:

- At the end of each stroke the air pressure will drop abnormally as the air motor begins to fill.
- At the same time the A and B pump outlet pressures will drop abnormally due to the feed pump's respective air motor's reduced pressure.
- The decrease in the pump outlet pressures causes the flow rate at the dispense gun to be reduced.
- Once the air motor has filled with air, all air pressures and flow rates will return to normal until the end of the next stroke.
- The decreased pump outlet pressure may affect the feed pumps' checking action, and thus mix ratio, resulting in the dispense of what appears to be poorly mixed material.
- Changing air pressure changes the compression of the component A hose and material. This causes an off ratio condition until pressures stabilize. Equipment air supply pressure must always stay above the motor regulator setpoint.

## Pump Troubleshooting Overview

### Pump Cavitation

Under normal operation, when the feed pump pressures are balanced, component A and component B outlet pressures are consistent.

Some up or down adjustments in feed pressures will be necessary to keep the pumps' outlet pressures balanced. This is due to viscosity differences in the two materials, volumetric ratio, and required flow rate. Because of the viscosity difference between the two materials, most of the balancing effect comes from adjusting the component A pressure. For ratios higher than 1:1, the component B pressure should be set only as high as necessary to avoid cavitation at the desired flow rate. For 1:1 ratio there is equal balancing from component A and component B pressure.

If either the A or B pump does not completely fill with material on intake, the failing pump's material output is interrupted at the beginning of the next stroke. This is referred to as *cavitation*.

Pump A cavitation is detected by observing the inlet pressure gauges on pump A and pump B immediately after changeover. When cavitation occurs, the proportioner pump outlet pressure gauge drops and the pump A outlet pressure gauge shows an increase in pressure, as described previously.

B pump cavitation is detected by observing the B pump inlet pressure gauge immediately after pump top changeover. When cavitation occurs, the B pump outlet pressure gauge drops.

If the amount of cavitation is moderate, the pressure gauges return to their normal readings at some point during the downstroke of the failing pump.

During pump A cavitation, the pressure drop may cause a noticeable reduction in flow rate at the dispense gun. Additionally, the interruption in the pump A material output may cause component B-rich material to dispense, which may appear as poorly mixed material.

During B pump cavitation, the interruption in the B pump material output may cause component A-rich material to dispense, which may appear as poorly mixed material.

### Pump Failure to Seal

Under normal operation, the output of the component A and component B pumps depends upon proper sealing of their internal packings.

If packings fail to seal properly, the pump material output, and thus the output pressure, is reduced. Depending on the location of the failure, the pressure reduction may occur on the pump upstroke, downstroke, or both strokes.

### Component B Pressure Relief Valve

The proportioner includes a spring-loaded, overpressure relief valve, which bypasses component B back to the supply when pressures exceed 3400 psi (23 MPa, 234 bar).

## Troubleshooting Guide: Feed pumps

Problem	Cause	Solution
Erratic feed pump speed.	Pump cavitation.	Bleed air from pump.
	Pumping too fast.	Turn down air pressure regulator.
	Improper pump loading.	Increase ram down pressure Ram valve not in down position.
	Pump lower not performing.	Rebuild pump
Material leaking from top of pump	Loose packing nut.	Retighten.
	Worn throat seals.	Rebuild pump, replace seals.
Feed pump fails to cycle	Air supply off.	Check air valves/line pressure. Turn on if required.
	Air pressure too low.	Increase air pressure on respective feed pump air regulator.
	Stalled air motor.	Motor icing (warm up). Check air filter and lubrication.
Ram fails to move up and down	Lack of air pressure.	Turn on or increase air supply pressure to ram.
	Ram failure.	Check and rebuild.
Material leaking past follower plate seal (small amount of leakage is normal)	Too much ram pressure.	Reduce ram down pressure on ram air pressure.
	Worn wiper seals.	Replace.
	Dented container.	Straighten or replace container.

## Troubleshooting Guide: 8900 Proportioner

Problem	Cause	Solution
Inconsistent material mix	Material inlet pressures are not set correctly. Erratic feed pump.	Follow flow rate procedures and ram feed pump troubleshooting guide.
	Mix elements not assembled correctly or need to be replaced.	Fix or replace.
	Cylinder cups are bypassing material.	Replace cylinder cups.
	Material outlet hoses are not sized correctly (pressures not balanced).	Call Graco Tech Service - (800) 543-0339
	Material ball valves are bypassing.	Rebuild/replace.
	Insufficient air supply to material supply pumps.	Verify consistent air supply.
	Purge valve open (if applicable).	Close during operation.
Meter pressures never change	Broken material gauge(s).	Replace.
Meter will not shift at the end of the stroke.	Limit valve not working correctly.	Rebuild/replace, see page 45.
	No material inlet pressure.	Verify.
	No air supply to limit valve.	Verify.
Meter will not move	Material inlet pressure not high enough to drive meter.	Verify low pressure on the gauges before increasing.
	4-way ball valve orientation incorrect.	Check, fix.
	Dispense valve closed.	Open.
	Blockage in material hose.	Depressurize system and repair.
	Blockage in meter assembly.	Depressurize system and repair.
Material leaking from meter end caps	Worn seals.	Replace.
	End caps loose.	Hand tighten with wrench provided.
Meters not balanced	Improper operation of supply pumps.	Check for proper operation of material supply pumps. Each should have adequate material supply. Reasonably constant and balanced meter inlet and outlet pressures indicate proper pump function. If flow rate is increased by increasing A pump pressure, increase B pump pressure proportionally to balance meter inlet and outlet pressures.
	Inadequate material supply to pumps.	
Meter outlet pressure too high, metering inaccurate, decreased flow rate, non-uniform mix (streaking)	Curing material in the mixer or blockage of either mixer inlet port (check valves/injector valves plugged).	Clear blockage.
Incorrect ratio check and reduced flow rate	Material may be bypassing rather than flowing through the meter.	Check for leakage in meter seals and cups.
Inaccurate metering	Air in the material or trapped in the pumping and metering components.	Bleed the air from the pump.

## Troubleshooting Guide: Manifold/Mixer

<b>Problem</b>	<b>Cause</b>	<b>Solution</b>
Poor mix quality.	Dirty mixer.	Disassemble Tri-Core mixer, clean housing and end caps, and replace mix elements.
	Inadequate mixing.	Add mixer with more elements or larger ID mixer.
	Dirty mixer and gun.	Replace flex mixer or clean Tri-Core mixer and gun.
	Tri-core mixer assembled improperly.	Reassemble with scribe lines on end caps aligned.
	Fouled or plugged component B injector.	Clean or replace injector.
	Cavitation due to ram air control valve not in DOWN position.	Place control valve in DOWN position.
	Cavitation due to low ram pressure.	Increase to required operating pressure.
Reduced flow rate.	Dirty mixer.	Disassemble Tri-Core mixer, clean housing and end caps, and replace mix elements.
	Dirty mixer and gun.	Replace flex mixer or clean Tri-core mixer and gun.
	Leaking component B shutoff valve.	Repair or replace valve.
Poor purge quality.	Leaking component B shutoff valve.	Repair or replace valve. May require solvent flush after valve replacement.
Abnormally high B pump outlet pressures.	Fouled or plugged component B injector.	Clean or replace injector.
	Feed pressure too high.	Reduce feed pressure.
Abnormally high pump A outlet pressures.	Restriction in gun or hose, plugged check valve.	Clean out gun. Inspect for cured material in check valve.
Soft spots or color change relating to changeovers.	Pressures are out of balance.	Adjust pressure settings on A and B supply pumps to balance outbound ram pressure too low on feed pump.

## Component B Injector

In most dispense systems, an injector is included in the component B fluid line. This injector adds back pressure to the system and provides the necessary pressure balance between component A and component B to achieve the proper ratio and mix.

If the injector becomes fouled with mixed material, the pressure indicated on the B pump outlet gauge will increase and upset the pressure balance, resulting in the dispense of poorly mixed material.

If the injector becomes completely plugged, only component A is dispensed from the gun and the B pump outlet pressure will increase until the relief valve discharges.

If the injector valve sticks, it can react sluggishly causing soft spots after valve triggering or changeover.

Keep the injector clean. Inspect the housing tip and needle end for dents or scratches. Lapping the needle to the housing with automotive lapping compound will recondition the seat/needle. When reassembling the injector, tighten the nut 2-2.5 turns after the slack is taken up.

It is good practice to have a clean injector on hand. A fouled injector can then be replaced quickly, and thoroughly cleaned and held for future use.

## Preventive Maintenance

1. Air supply: Oil level in main air line lubricator should be checked daily and refilled when necessary with SAE 10W non-detergent oil. Adjust to dispense 1 drop per minute during operation.

Main air line filter should be drained as required. Excessive amounts of water in the system will reduce machine performance.

2. Housekeeping: Spilled materials on any part of the equipment should be cleaned up promptly. Your system is precision equipment and should be maintained as such. A light coating of petroleum jelly on components will often prevent spilled material from sticking to equipment.
3. Pumps: Pump packing should be tightened daily the first week of operation and weekly thereafter.
4. When using Throat Seal Lubricant (TSL) or ISO oil, the lubricant should be maintained at an adequate level in the pump packing reservoir. These lubricants prevent material from sticking to pump rods, extends packing life, and protects material from contamination from the atmosphere.



Use ISO oil when dispensing moisture-sensitive materials.

Meter: Maintain TSL or ISO oil in reservoir if used; grease zerk fitting. Clean up spills as soon as possible to prevent damage to the meter.

5. Mixer: With most materials, frequent use of equipment is all that is needed to prevent internal curing. Some materials have a tendency to cure slowly on the walls of the mixing chamber. Experience will dictate how often the mixer or mixer elements should be thoroughly cleaned or replaced.
6. O-rings/Seals: O-rings and seals will be damaged if soaked in solvents. When reusing, wipe with solvent and dry immediately.

# Service and Repair

## Repair the Cylinder (Fixed Ratio)



- Relieve pressure throughout the 8900 Proportioner assembly. Follow the pressure relief procedure on page 31.
- Reference numbers shown in parentheses in Service and Repair procedures refer to references in figures and parts lists.

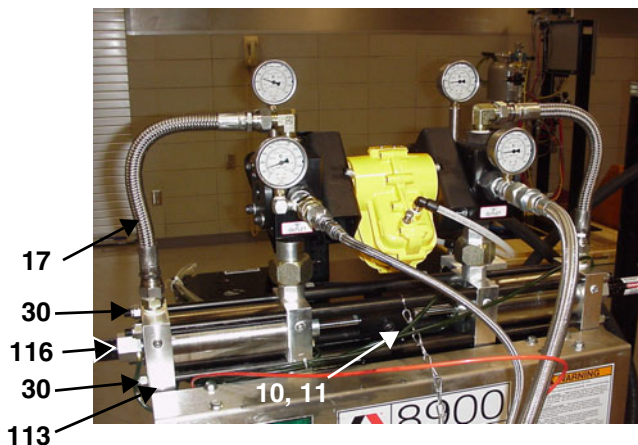

**FIG. 29: Fixed Ratio 8900**

- Disconnect hose (17) on cylinder end manifold, FIG. 29.
- Remove guard tube (116).
- Loosen and remove 4 locknuts (30).
- Loosen nut (10) on coupling (11) and disconnect pump rod from coupling.



If the entire cylinder needs to be removed and serviced at another location, loosen and remove screws (49). Then loosen union (9) to remove the cylinder assembly from unit. See page 49.

- Pull on cylinder block (113), FIG. 31. Cylinder should come apart.
- Remove rod and piston assembly from cylinder.
- Remove packing nut (115) from cylinder block (113) and remove throat packings and glands (110, 111, 112).

- Remove packing nut (103) from opposite cylinder end cap (106) and remove throat packings and glands (110, 111, 112).
- Remove piston assembly (106, 107) from rods (101, 102).
- Replace V packings and glands on both ends with new ones and reassemble in reverse order of disassembly.
- Replace cylinder end o-rings (109) on each cylinder end cap. Apply grease to each to help hold o-ring into end cap.
- Push piston assembly through cylinder block (113).



Use grease generously during reassembly.

- Replace o-rings (114) on each packing nut and screw, then screw packing nut back into cylinder end caps. Hand tighten until firmly seated on packings, then wrench tighten 1/4 turn.
- Push cylinder assembly back together.
- Complete reassembly of the cylinder in reverse order of disassembly.



Use threadlocker (118) when reassembling rods (101, 102). Torque to 55 ft-lbs (74.25 N•m).



**FIG. 30: Variable Ratio 8900**

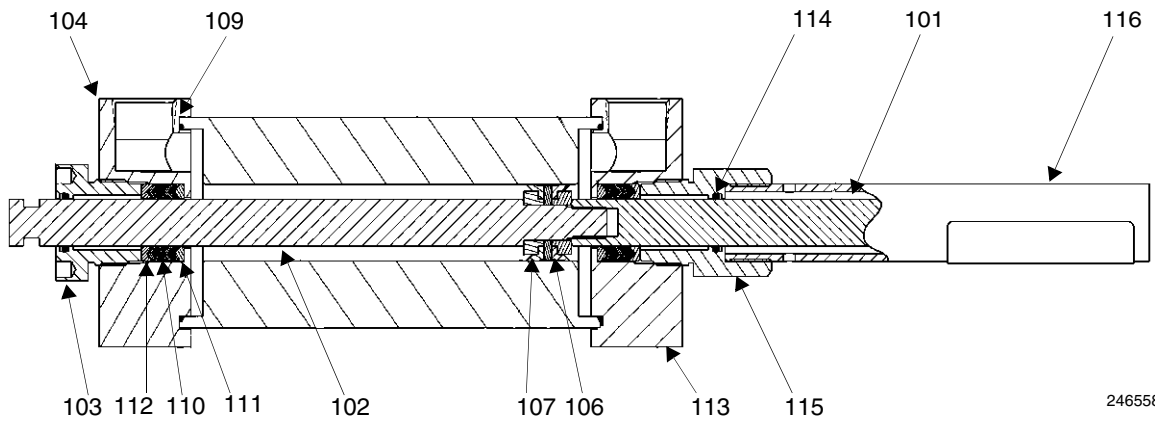
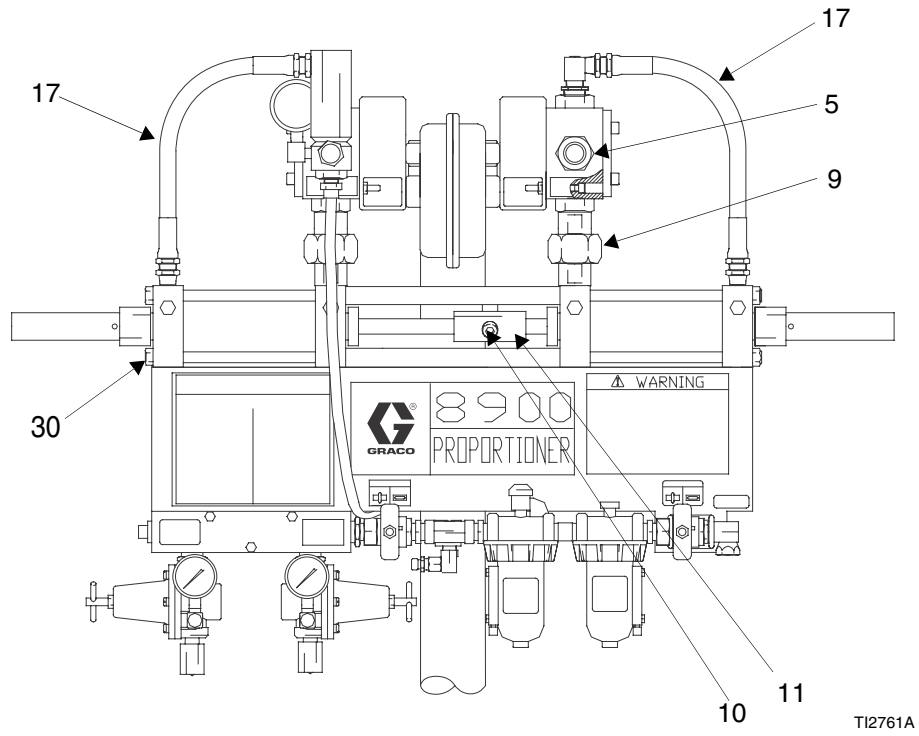

FIG. 31

## Replace Air Valve

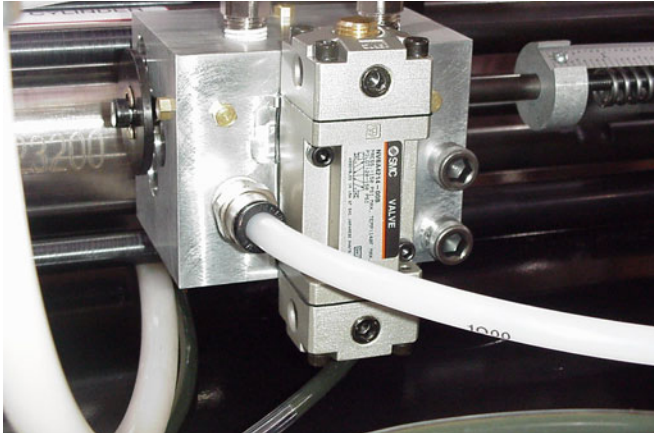

FIG. 32

1. Unscrew 2 socket head cap screws (311), FIG. 33.
2. Pull complete air valve assembly off cylinder and connecting rod assembly.
3. Remove retaining ring and plate off end and pull rod through.
4. Remove retaining ring off appropriate air valve (303), pull out valve (304) and replace with new valve.
5. Reassemble in reverse order of disassembly. Make sure not to remove spacer (305) during disassembly. This spacer sets correct alignment of valves.
6. Reattach air valve assembly to the 8900 cylinder block and connecting rod assembly.

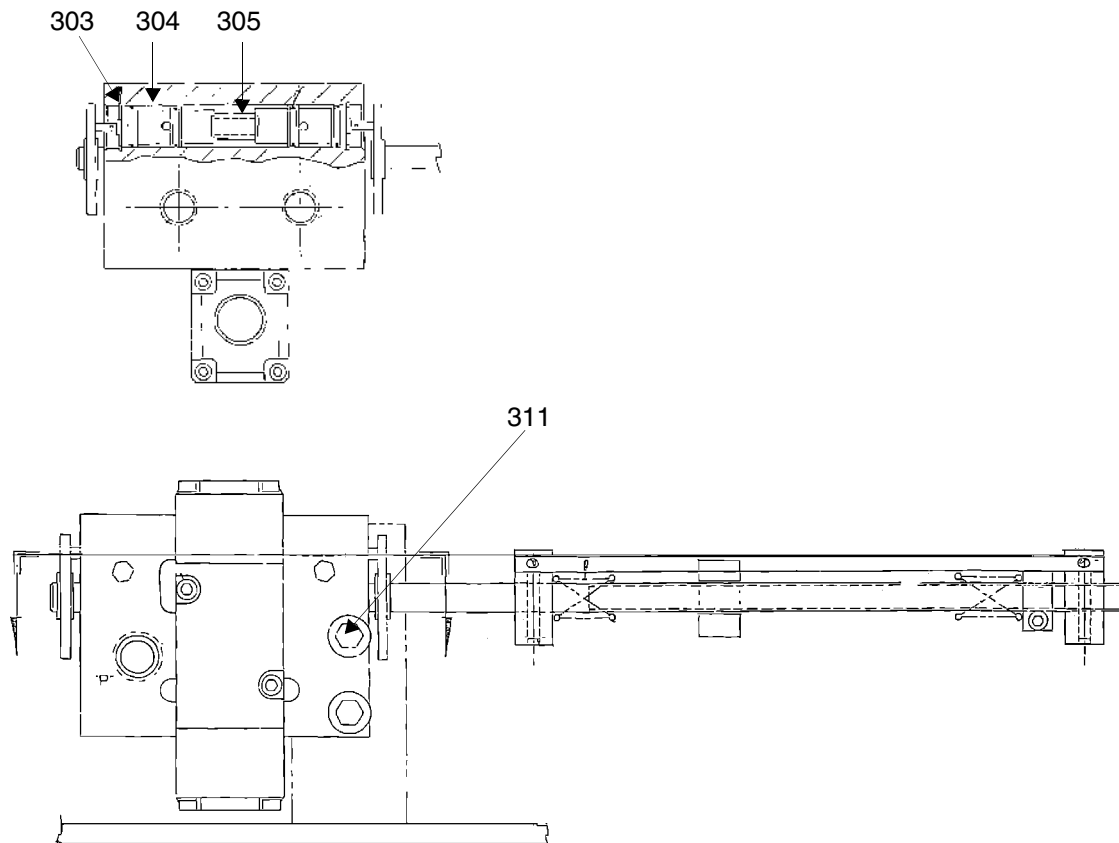

FIG. 33

# Disassemble Fluid Valve



FIG. 34

1. Relieve pressure and turn off feed supply units. Close air valve.
2. Remove valve assembly from 8900 cylinder. Take off hose (17), union (9), fitting in (5), fitting out (5). See FIG. 31.
3. Remove 4 socket head cap screws (415, FIG. 35).

4. Pull off end cap (413).
5. Pull out ball passage (411) with backup ring (409), packing o-ring (410), and bushing (408).
6. Remove packing assemblies consisting of seal (402), o-ring (403), bushing (404), o-rings (406, 407), and connector (405).
7. 4-way valve must be installed so that flow paths marked on shaft (see illustration below) are 90° out of phase with each other. Stamped indicators on shaft end of valves show material flow paths. The 8900 Proportioner will not cycle if the valves are not in proper phase with each other.

 When reassembling, apply grease to all o-rings and bearings.

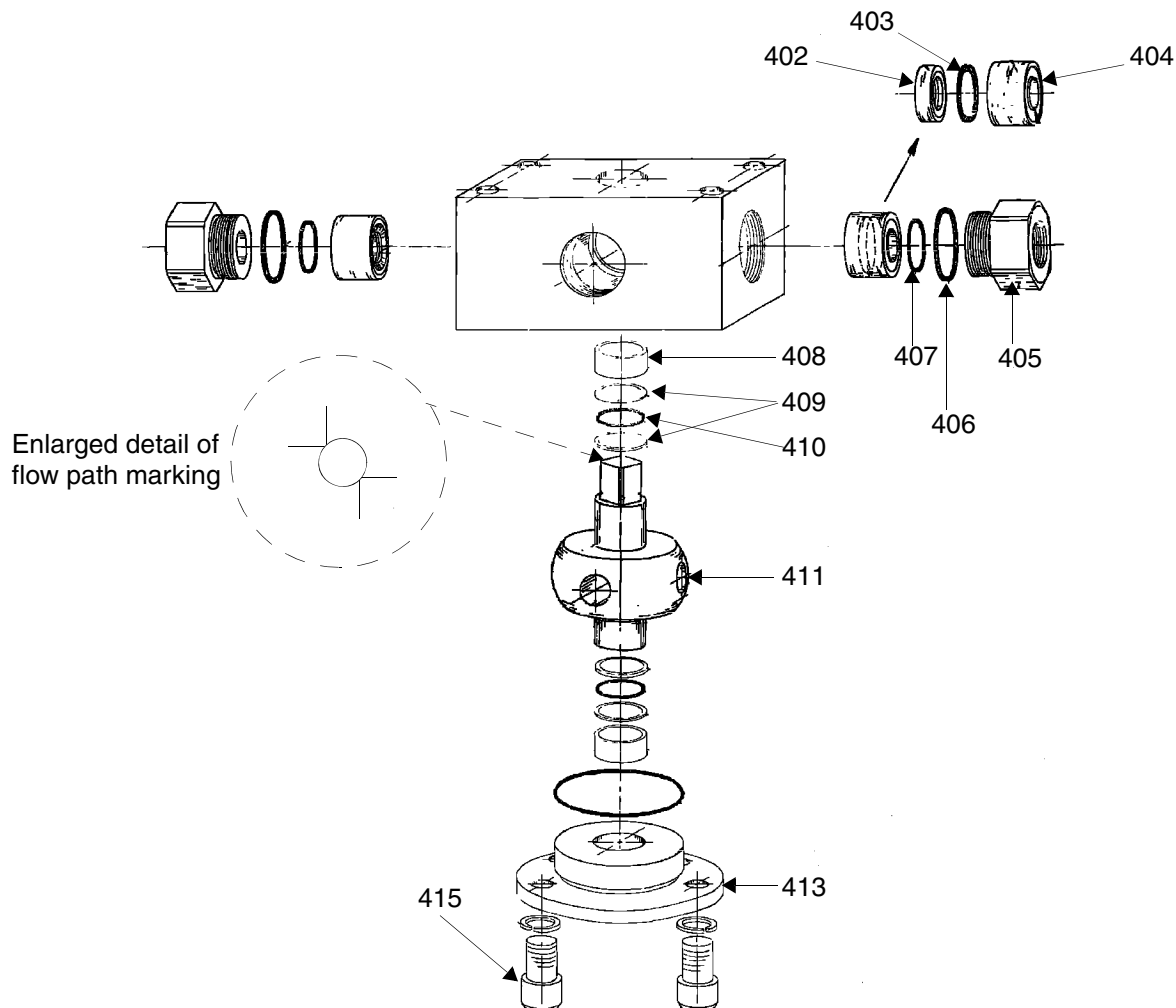

FIG. 35



# Parts

## 8900 Proportioner, Fixed Ratio

Fixed Ratio	Assembly No.	Item 7		Item 14				
		Part Number						
		570367	570369	570366	246558	C24145	570366	570367
		Quantity						
1:1	570371					2		
1:1	24C972		2					
2:1	570372	1				1		
2.5:1	570373		1				1	
4:1	570374			1		1		
5:1	570375		1					1
9:1	246557				1	1		
10:1	570376		1			1		

Ref. No.	Part No.	Description	Qty.
28	590385	TUBE, nylon; 0.375 OD; 6 ft	*
30	101926	LOCKNUT; 1/2-20 NF	8
31	C29034	WRENCH, spanner	1
32	156172	FITTING, swivel; 3/4 nps x 3/4 npt	3
38	C03190	RING	2
39	C23269	CHAIN	1
40	C24140	MANIFOLD, lube	1
41	949666	AIR CONTROL; see page 53	1
42	C30021	U-BOLT; 3/8-16 UNC	2
43	237112	VALVE, relief	1
44	113344	UNION, swivel; 1/2-14 npt x 3/4 npsm	2
45	113187	CONNECTOR, tube, 1/2 OD x 1/2 npt	1
47	061134	HOSE, nylon; 1/2 in. OD, 1.4 MPa, (14 bar, 200 psi), 6'	1
48	105209	SCREW; 10-32 UNF x 7/8 in.	2
49	100101	SCREW; 3/8-16 UNC x 1 in.	10
50	100131	NUT; 3/8-16 UNC	6
51	100133	WASHER, lock; 7/16 in.	6
52	965785	BASE	1
57	100840	ELBOW; 1/4-18 npt	1

\*EPDM replacement part available in kit 289401.

Ref. No.	Part No.	Description	Qty.
1	C24016	ARM, trip	1
3	187877	TUBE, gauge	2
4	102814	GAUGE, fluid pressure	4
5	624545	T-FITTING; 3/4 npt(m) x 1/4 npt(f)	4
6	157785	UNION, swivel; 3/4 nps x 3/4 npt	4
7		CYLINDER; see table above; see page 52	1
8	C19411	CONNECTOR; 3/8 npt x 3/8 tube	1
9	C24042	UNION; includes 9a	2
9a*	105802	O-RING; fluoroelastomer	2
10	110343	SCREW; 1/2-13 UNC x 1.75 in.	1
11	C23016	COUPLING	1
12	C24013	SPACER	4
13	C24053	COUPLING	1
14		CYLINDER; see table above; see page 52	1
15	16E304	COUPLING	1
17	552272	HOSE; 3/4 npt, 4000 psi (28 MPa, 276 bar)	2
19	100214	LOCKWASHER	4
20	C19829	SCREW; 5/16-18 x 2.5 in.	4
21	111303	NUT; hex	4
22	C24052	BRACKET, valve mounting	2
23	109212	SCREW; 3/8-24 x 3/4 in.	8
24	16E287	ACTUATOR, pneumatic	1
25	C24029	VALVE, 4-way	2
26	C24014	VALVE, limit	1
27	120753	ELBOW, 90°; 1/4 npt x 3/8 in. tube	1

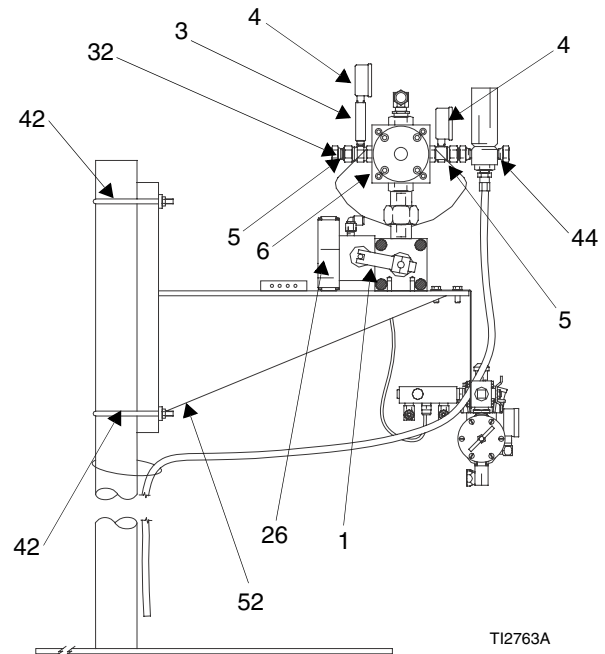

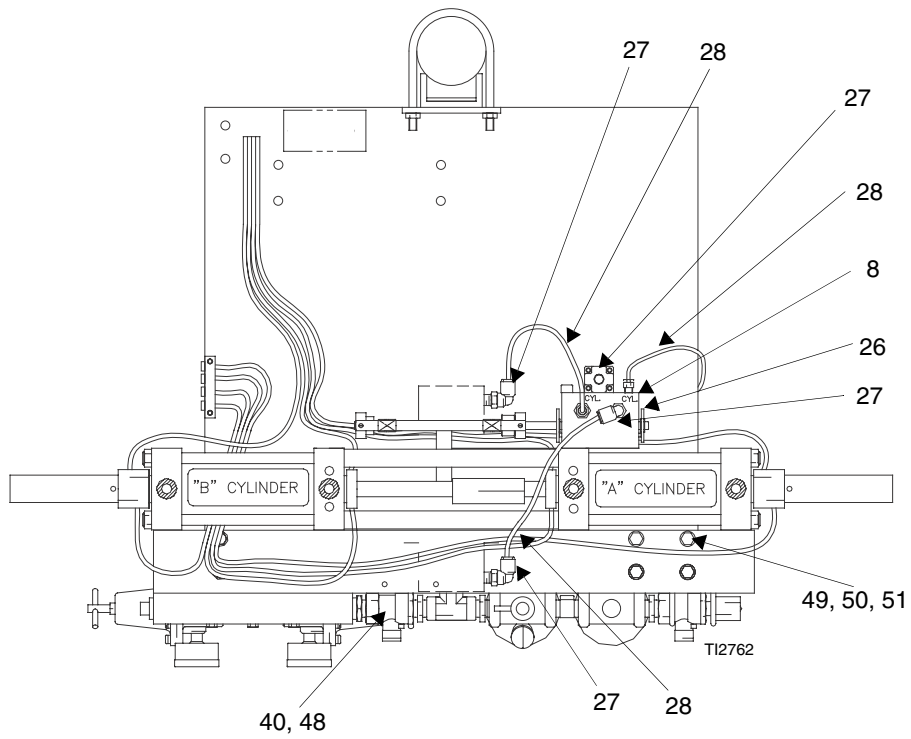
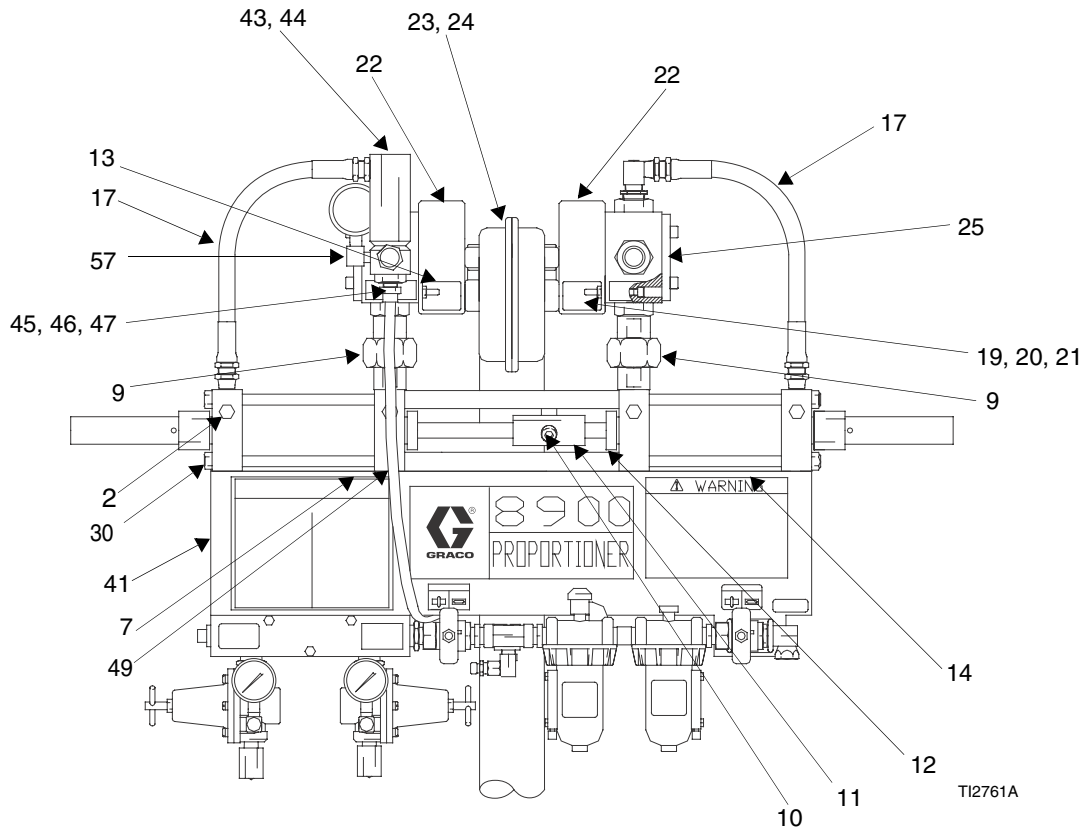

# 8900 Proportioner, Variable Ratio

Variable Ratio	Assembly No.	Item 1		Item 2	
		Part Number			
		570367	570369	570366	570369
		Quantity			
1:1 - 4:1	570377	2			
2:1 - 8:1	570378	1			1
5:1 - 20:1	570380	1			1

Ref. No.	Part No.	Description	Qty.
1		CYLINDER; see table above and page 52	
2		CYLINDER; see table above and page 52	
4	624545	FITTING, TEE 3/4m run X 1/4f	4
6	157785	FITTING, union, swivel	4
7	102814	GAUGE, pressure, fluid	4
8	156172	FITTING, union, swivel	5
9	552272	HOSE, PTFE 3/4-18" 5000 psi npt(m)	2
12	C23016	COUPLING, pair	2
13	C19854	SCREW, cap, socket head	2
14	C24016	ARM, trip	1
15	C24422	ROD, tie	8
16	101926	NUT, locking, metallic	16
17	C23280	8841-4-A, beam assembly	1
18	C24420	SCREW, ratio adjusting	1
19	C24419	PLUNGER	2
20	C29031	BAR, uni	1
21	C29023	ASSEMBLY, fulcrum	1
22	C29037	STOP, unibar	2
23	C19852	SCREW, cap, socket head	2
24	16E287	ACTUATOR, pneumatic	1
25	16E324	COUPLER, long	1
26	C24418	BRACKET, 3/4 valve mounting	2
27	C24029	VALVE, 4-way	2
29	109212	SCREW, cap, socket head	8
30	C19829	SCREW, cap, socket head	4
31	111303	NUT, hex	4
32	100214	WASHER, lock	4
33	C23276	MONITOR, scale	1
34	C19798	SCREW, cap, socket head	2
35	100018	WASHER, lock, spring	3
36	100321	NUT	1
38	C24014	VALVE, limit	1
39*	C24042	FITTING, union, assembly	2
40	C24417	STUD	2
41	16E321	COUPLER, 3/4 in. sq x 5/8 in. sq	1
43	100847	FITTING, lubrication	2
44	C24442	PLATE, designation	1
45	C29034	TOOL, spanner wrench	1

Ref. No.	Part No.	Description	Qty.
46	C23269	CHAIN	1
47	C03190	RING	2
49	100840	ELBOW, street	4
53	C29043	BUSHING, ball	2
54	160327	FITTING, union, adapter, 90 degree	2
55	157191	FITTING, adapter	1
56	237112	VALVE, relief	1
57	156022	ADAPTER	1
58	205439	COUPLING, hose	1
59	061134	HOSE, nylon	6
60	C24140	MANIFOLD, lubrication	1
61	105209	SCREW, cap, socket head	2
62	949666	AIR CONTROL; see page 53	1
63	100004	SCREW, cap, hex head	8
64	100131	NUT, full hex	6
65	100133	WASHER, lock	6
66	965785	BASE, weld mount 8900 VR	1
67	C30021	BOLT, u	2
68	626814	SPACER, .75 od x .45 id x .50 lg alum	8
72	120753	FITTING, elbow, male, 90 degree	2
73	590385	TUBE, 3/8 in. OD nylon 3.6 ft	*
74	120389	FITTING, tube	2
75	513754	COLLAR, shaft 1.250 cs split	2
79	113344	UNION, swivel	1

\*EPDM replacement part available in kit 289401.

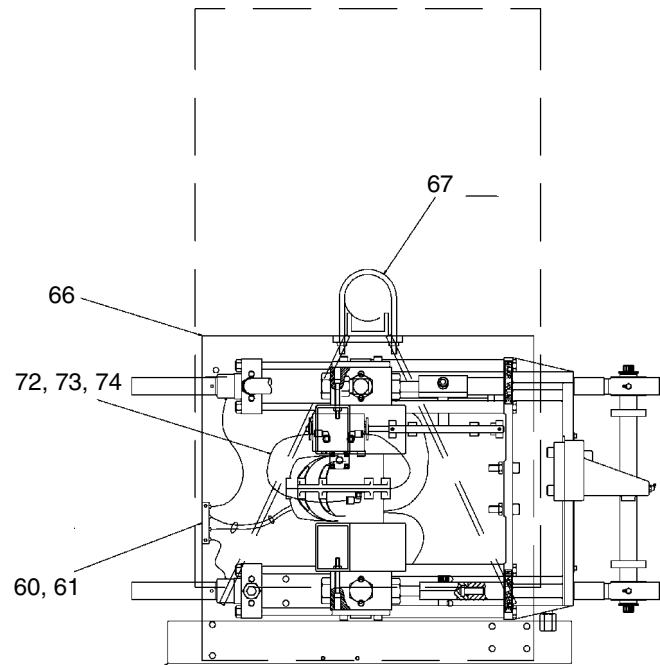

Top View

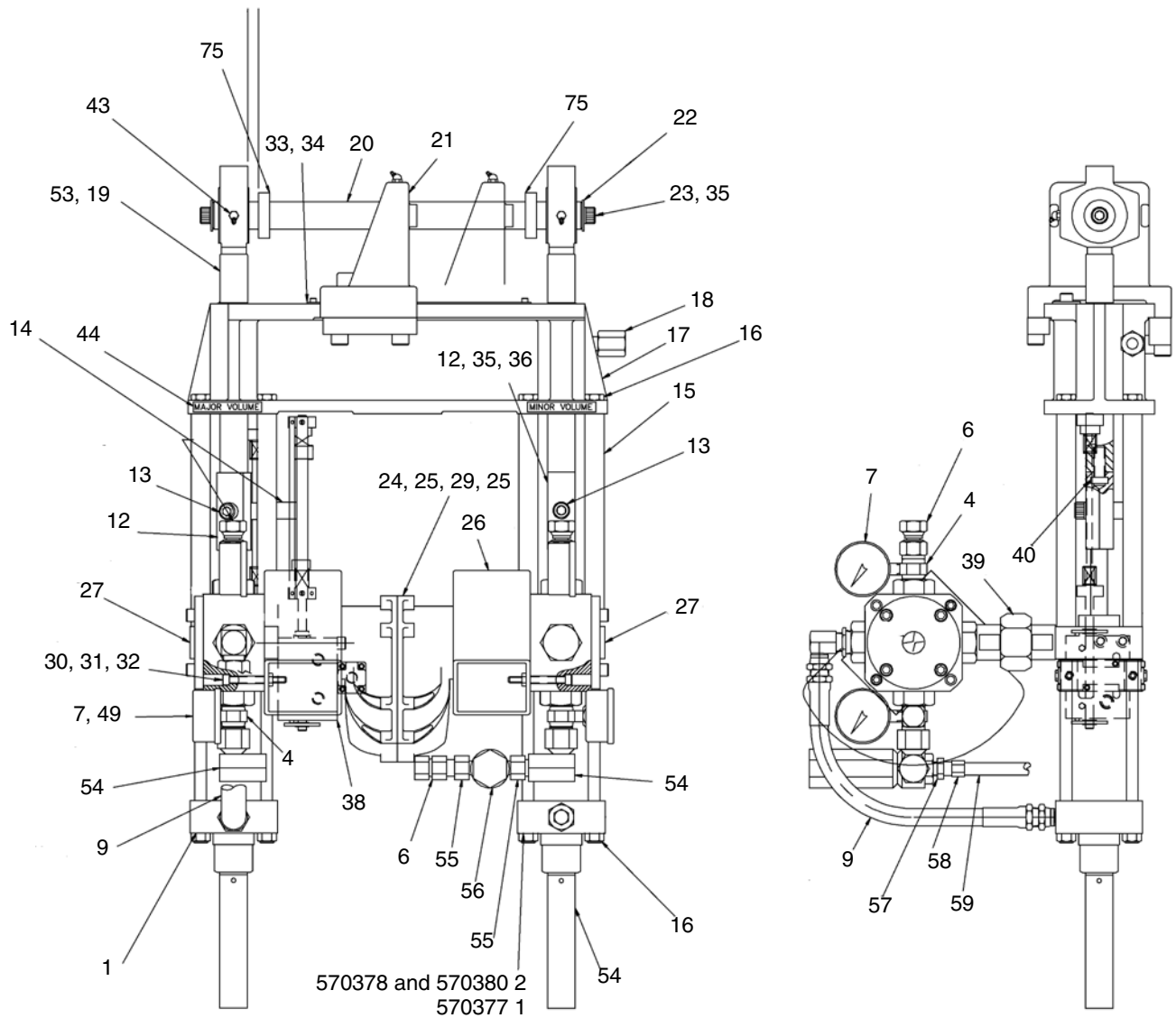

# Cylinder Assemblies

(ref. nos. 7 and 14 FR, 1 and 2 VR)

## Part No. 246558

Model 246557 only

## Part No. 570366

Models 570373 and 570374 only

## Part No. 570367

Models 570372, 570375, and 570377 only

## Part No. 570369

Models 570371 and 570376 only

## Part No. C24145

Models 570371, 570372, 570374, 246557, and 570376

### Ref.

No.	Part No.	Description	Qty.
101	C24054	SHAFT, piston, outer	1
102	C24055	SHAFT, piston, inner	1
103	C24022	NUT, packing	1
104	C24026	BLOCK, cylinder, inside	1
105	15C180	CYLINDER, 111; 246558 only	1
	C23171	CYLINDER, 250; 570366 only	
	C23200	CYLINDER, 500; 570367 only	
	C23137	CYLINDER, 100; 570369 only	
	C23136	CYLINDER; 1000; C24145 only	

Ref. No.	Part No.	Description	Qty.
106	15C181	SPACER; 246558 only	1
	C23431	SPACER, 570366 only	
	C23460	SPACER, 570367 only	
	C23398	SPACER; 570369 only	
	C05031	SPACER; C24145 only	
107	15C182	PACKING, cup; 246558 only	2
	C23318	PACKING, cup; 570366 only	
	C23350	PACKING, cup; 570367 only	
	C23282	PACKING, cup; 570369 only	
	C05032	PACKING, cup; C24145 only	
108	15C183	RING, backup; 246558 only	2
	C23547	RING, backup; 570366 only	
	C23515	RING, backup; 570369 only	
	C05029	RING, backup; C24145 only	
	C23574	RING, backup; 570367 only	
109*	C20278	O-RING; fluoroelastomer	2
110	C21002	V-PACKING; PTFE	10
111	C36244	GLAND, male	2
112	C36246	GLAND, female	2
113	C24023	BLOCK, cylinder, outside	1
114*	188554	O-RING, fluoroelastomer	2
115	C57617	NUT, packing	1
116	C57618	TUBE, guard	1
117	179788	LABEL, warning	1
118		SEALANT, thread lock	1

\*EPDM replacement part available in kit 289402

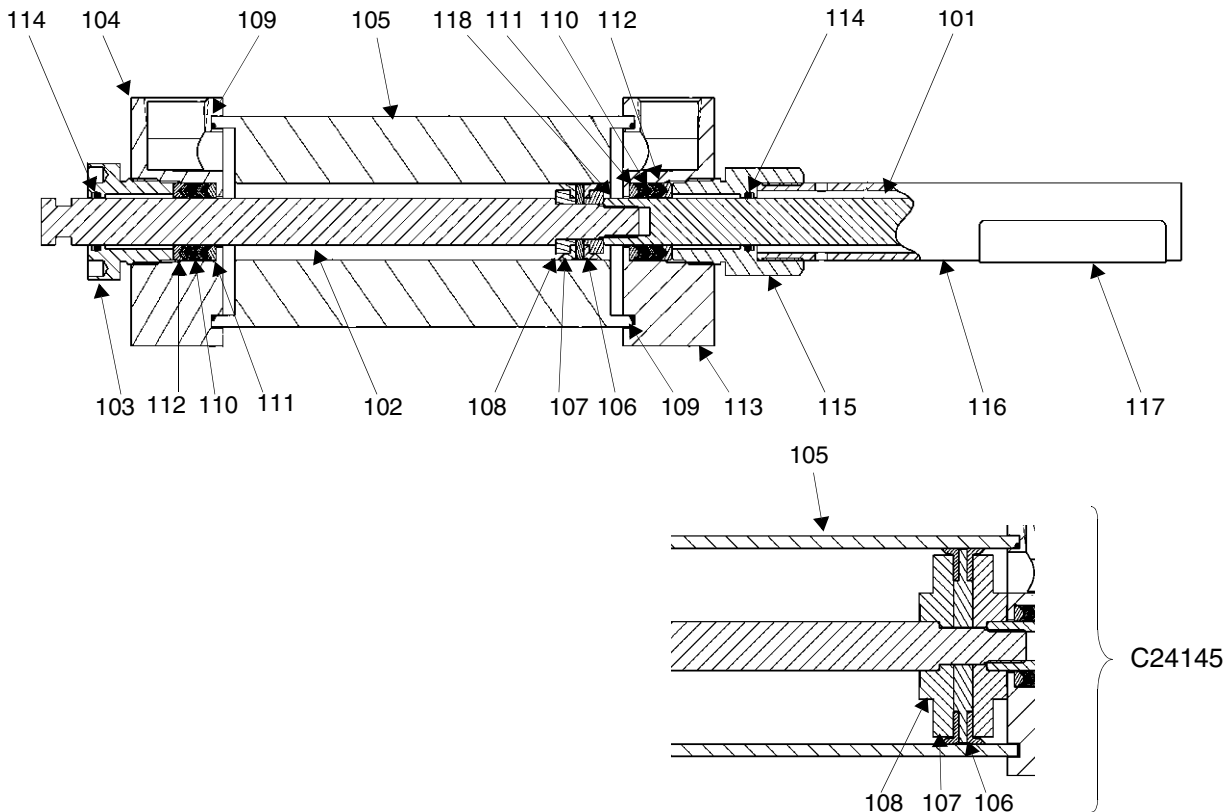

# Limit Valve

(ref. no. 26 FR, 38 VR)

## Part No. C24014

Ref. No.	Part No.	Description	Qty.
301	C20439	RING, retaining ext	4
302	C24008	WASHER	2
303	C20407	RING, retainer	2
304	C22064	VALVE	2
305	C24007	SPACER	1
306	C24051	MANIFOLD	1
307	100079	WASHER, lock, spring	2

Ref. No.	Part No.	Description	Qty.
308	C19977	SCREW, cap	2
309	C24012	VALVE, 4-way	1
310	C20852	FITTING, plug, 10-32	5
311	C19835	SCREW, cap socket head	2
312	C24017	ROD, trip, valve	1
313	C24009	SPRING, compression	2
314	C20068	PIN, spring	2
315	C24018	COLLAR, stop	2
316	C24019	INDICATOR, scale	1
317	C19146	SCREW, mach, slotted round head	2
318	C24020	COLLAR, clamp	1
319	C19264	PLUG, pipe plug 1/4 in.	3
320	C24016	ARM, trip	1

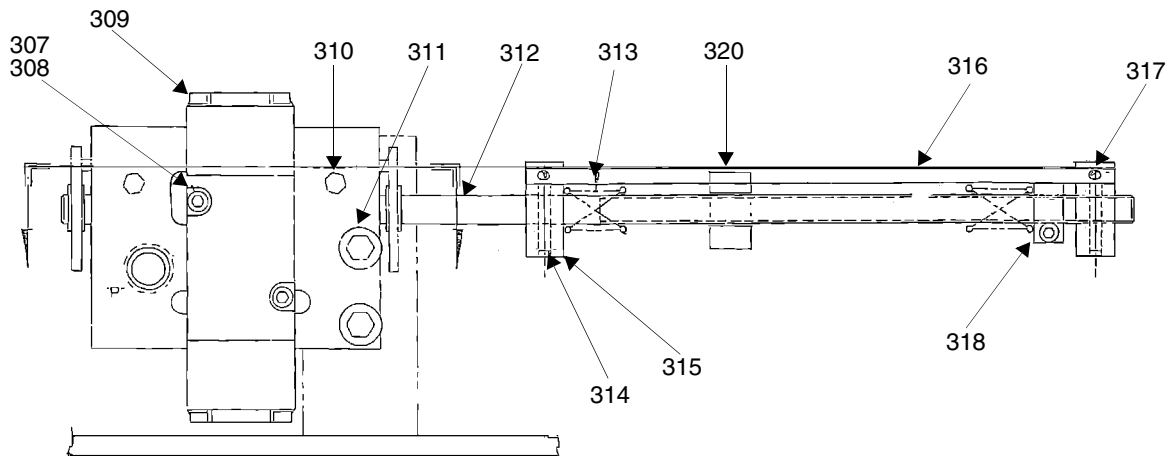
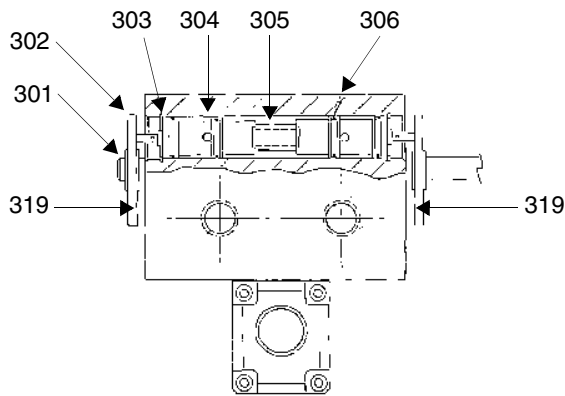

# Air Control

(ref. no. 41 FR, 62 VR)

## Part No. 949666

Ref. No.	Part No.	Description	Qty.
201	626086	BRACKET	1
202	624225	AIR MANIFOLD	1
203	157191	ADAPTER;	3
204	206197	AIR REGULATOR; 1/2 x 3/4 npt	2
205	100840	ELBOW; 1/4-18 npt	2
206	160430	GAUGE, air pressure	2
207	1554701	UNION, 90° swivel; 1/2-14 npsm x 1/4-14 npt	3
208	105170	SCREW; 1/4-20 UNC x 2 in.	3
209	100015	NUT; 1/4-20 UNC	5
210	100016	WASHER, lock	5
211	110225	VALVE, 2-way, vented; 1/2-14 npt	2

Ref. No.	Part No.	Description	Qty.
212	103475	TEE; 1/2 npt	1
213	100122	NIPPLE; 1/2-14 npt	2
214	214848	LUBRICATOR, air line	1
215	106149	FILTER, air; 1/2 npt	1
216	172124	NIPPLE; 1/2-14 x 3/8-18 npt	1
219▲	551206	WARNING LABEL	1
220▲	551207	INSTRUCTION LABEL	1
221	158990	AIR MANIFOLD	1
222	158491	NIPPLE; 1/2-14 npt	1
223	155495	UNION, 90° swivel; 1/4 npsm x 3/8 npt	2
224	162453	NIPPLE; 1/4 npsm x 1/4 npt	2
225	101748	PLUG; 3/8-18 npt	2
226	100361	PLUG; 1/2-14 npt	1
227	C19411	CONNECTOR; 3/8 tube x 3/8 npt	1
228	106285	U-BOLT; 1/4-20 UNC	2
229	C19394	ELBOW, 90°; 3/8 tube x 3/8 npt	1

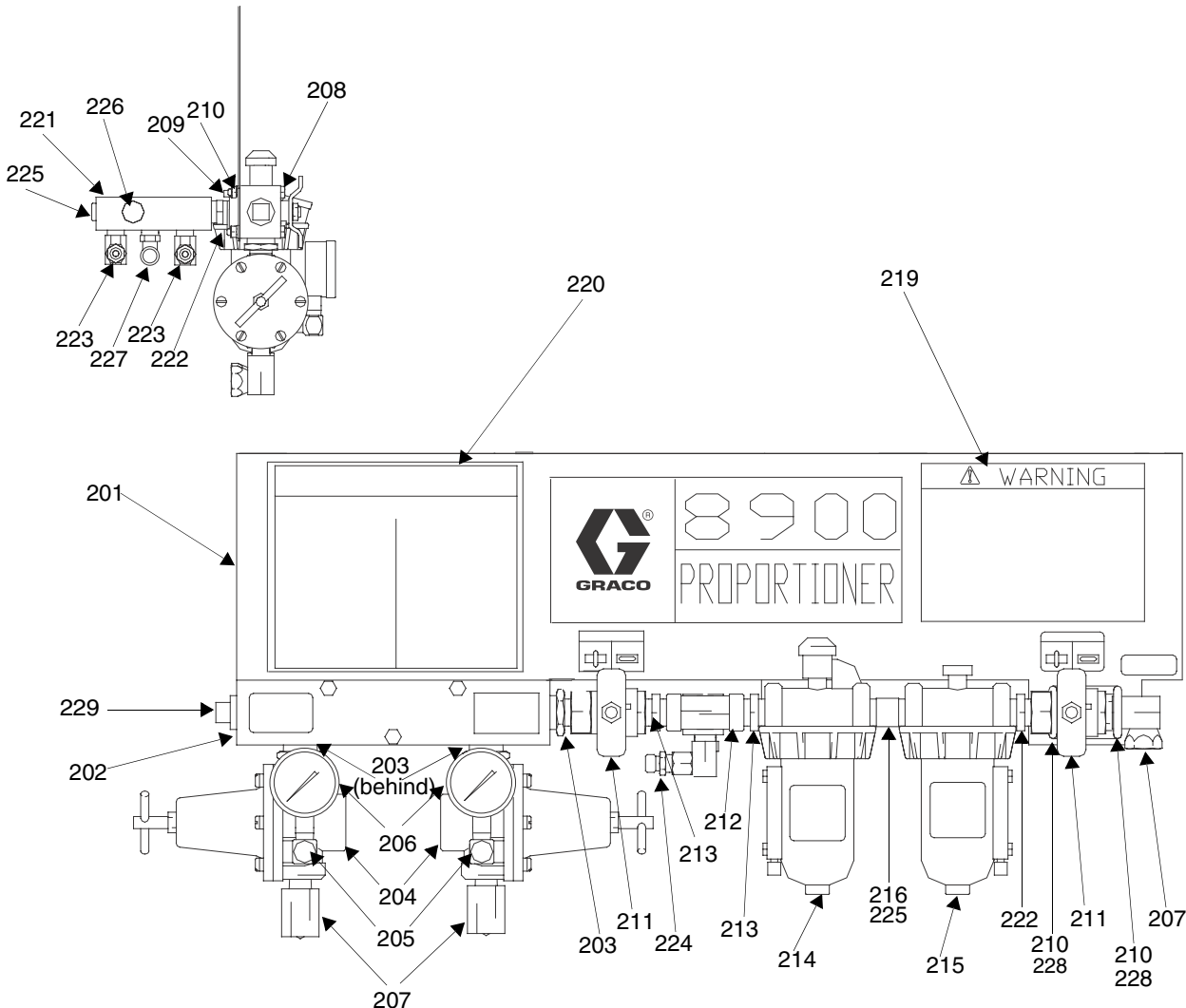

# 4-Way Valve

(ref. no. 25 FR, 27 VR)

## Part No. C24029

Ref.

No.	Part No.	Description	Qty.
401	C24030	BODY, valve	1
402	C24031	SEAL	4
403*	C24036	PACKING, o-ring	4
404	C24033	BUSHING	4
405	C24034	FITTING, connector	4
406*	C24035	PACKING, o-ring	4
407*	C24032	PACKING, o-ring	4

Ref.

No.	Part No.	Description	Qty.
408	C24037	BUSHING	2
409	C24038	RING, backup	4
410*	103611	PACKING, o-ring	2
411	C07068	BALL, passage	1
412*	C24040	PACKING, o-ring	1
413	C24041	CAP, end	1
414	100133	WASHER, lock	4
415	C19839	SCREW, cap, socket head	4

\*EPDM replacement part available in kit 289401.

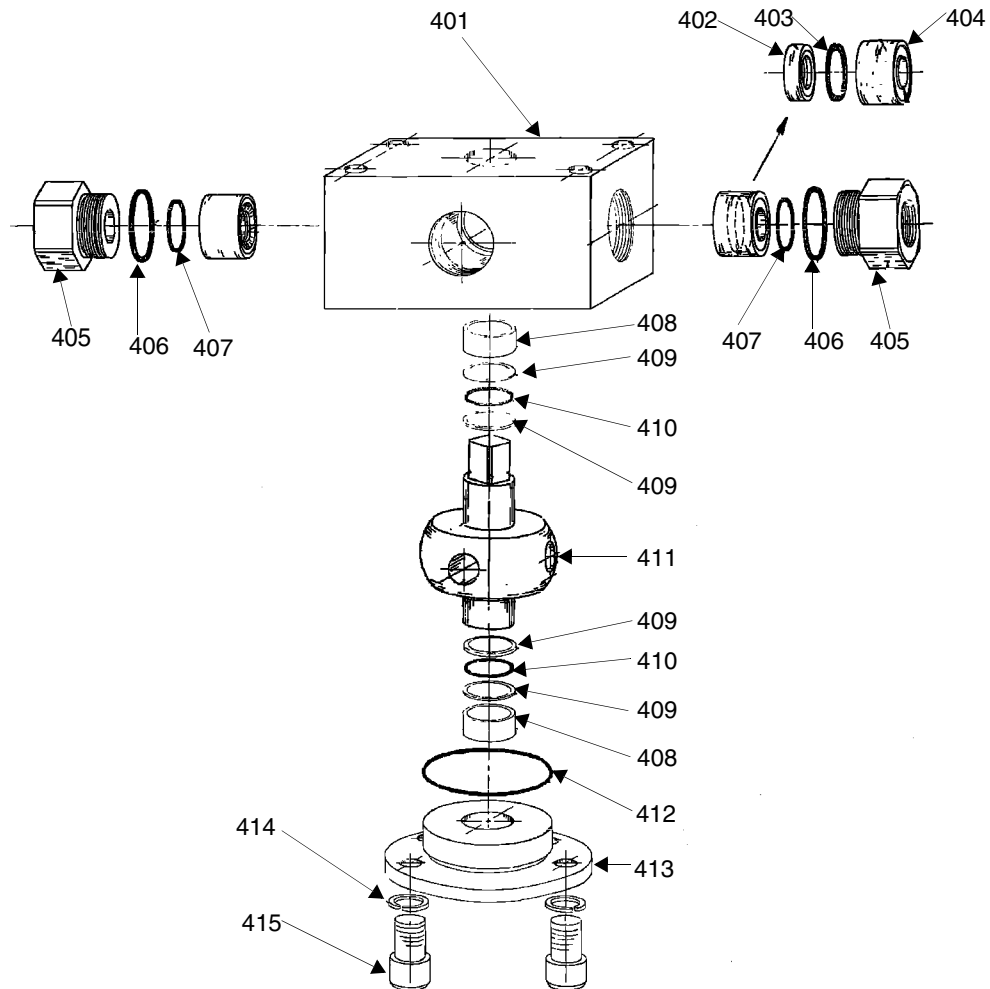

## Pump Feed Module Selection for Component A or Component B

### 20:1 President on 5 Gallon Ram

(See Graco Manuals 308026 and 306838)

#### Module No. 965571

Ref. No.	Part No.	Description	Qty.	Ref. No.	Part No.	Description	Qty.
4	237207	PUMP, President, 20:1	1	55	101533	WASHER, spring lock	1
13	222812	PLATE, wiper, 5 gallon	1	56	190265	SPACER	1
22	102556	RIVET, blind	4	57	238925	PISTON, ram, 5 gallon	1
24	156823	UNION, swivel	1	58	166552	CAP, cylinder	1
27	184147	SHIELD, 5 gallon ram	1	59	206726	BASE, and cylinder	1
35	113269	VALVE, ball, vented, .500	1	63	054123	TUBE, nylon 3.7 ft	*
36	155865	UNION, adapter	1	65	190256	CLAMP, support	2
37	237569	WIRE, assy, 25 ft	1	66	100680	SCREW, cap, hex head	4
42	156971	NIPPLE, short	1	67	101566	NUT, lock	4
43	104984	TEE, pipe	1	68	100023	WASHER, flat	4
44	113286	VALVE, safety	1	70	114320	FITTING, connector, 1/8 npt(f)	1
45	160701	ELBOW, street	1	71	115901	TRIM, edge, protection	2
47	237562	SUPPORT, pump	1	72	160327	UNION, adapter, 90°	2
48	113208	FITTING, tube	2	73	220179	VALVE, check	1
49	113896	VALVE, control	1	74	100896	FITTING, bushing, pipe	2
51	104765	PLUG, pipe headless	1	75	H45010	HOSE, fluid; nylon; 1/2 in. (13 mm) ID; 1/2 npsm(fbe); 10 ft (3.05 m) long	1
52	110318	REGULATOR, air, 1/4 in.npt	1	76	214656	HOSE, coupled, 61209, 10 ft	1
53	110319	GAUGE, pressure, air, 1/8 in. npt	1	77	109126	HOSE coupled, 10 ft	1
54	160107	NUT, cap	1	79	155470	UNION, swivel, 90°	1
				80	158491	FITTING, nipple	2

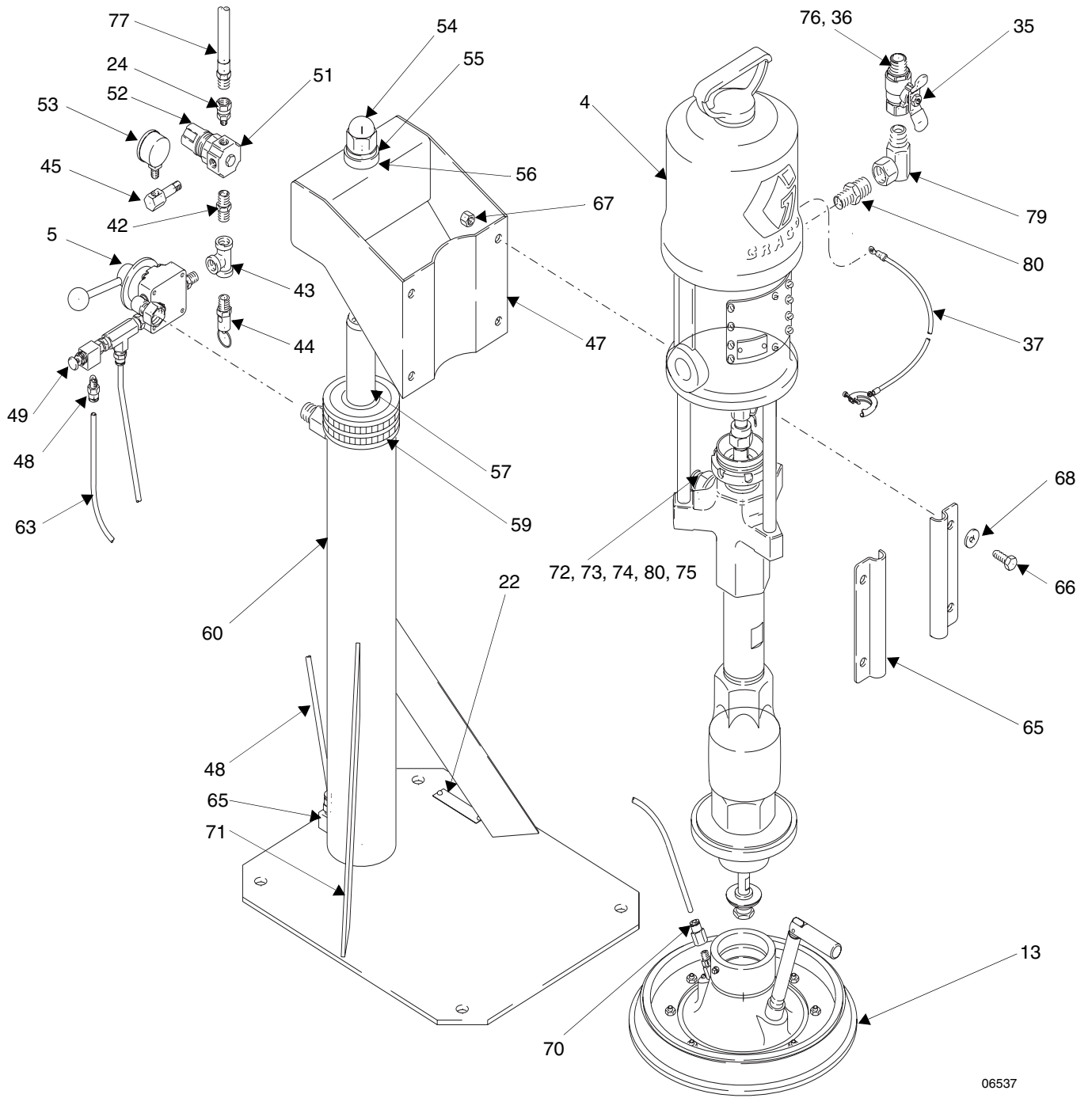

06537

## 34:1 Senator on 5 Gallon Ram

(See Graco Manuals 308026 and 306838)

### Module No. 965597

Ref. No.	Part No.	Description	Qty.	Ref. No.	Part No.	Description	Qty.
1	222769	PUMP, senator (4.5 cm)	1	35	110319	GAUGE, pressure, air, 1/8 in. npt	1
2	100468	SCREW, cap, hex head	4	36	104765	PLUG, pipe, headless	1
3	100133	WASHER, lock	4	37	155541	UNION, swivel, 90°	1
4	222812	PLATE, wiper, 5 gallon	1	38	238925	PISTON, ram, 5 gal.	1
7	101154	PIN, driv-lok	1	39	166533	SUPPORT, pump	1
10	102556	RIVET, blind	4	40	110225	VALVE, ball, vented	1
12	107144	SCREW, cap, hex head	1	45	237569	WIRE, assy, 25 in.	1
15	184150	SPACER, rod, elevator	1	46	180916	MANIFOLD, adapter	1
17	184147	SHIELD, 5 gallon ram	1	47	114003	VALVE, safety	1
22	206726	BASE, and cylinder	1	50	114320	FITTING, connector, 1/8 npt(f)	1
23	101533	WASHER, spring lock	1	52	160327	UNION, adapter, 90°	3
24	166552	CAP, cylinder	1	53	115901	TRIM, edge, protection	2
25	113208	FITTING, tube	2	55	220179	VALVE, check	1
26	113896	VALVE, control	1	56	157191	FITTING, bushing, pipe	1
29	160107	NUT, cap	1	57	215238	HOSE, coupled, 61220	1
30	054123	TUBE, nylon 3.7 ft	*	58	214656	HOSE, coupled, 61209, 10 in.	1
34	110318	REGULATOR, air, 1/4 in. npt	1	59	109126	HOSE, coupled, 10 in.	1
				60	156684	UNION, adapter, swivel	1

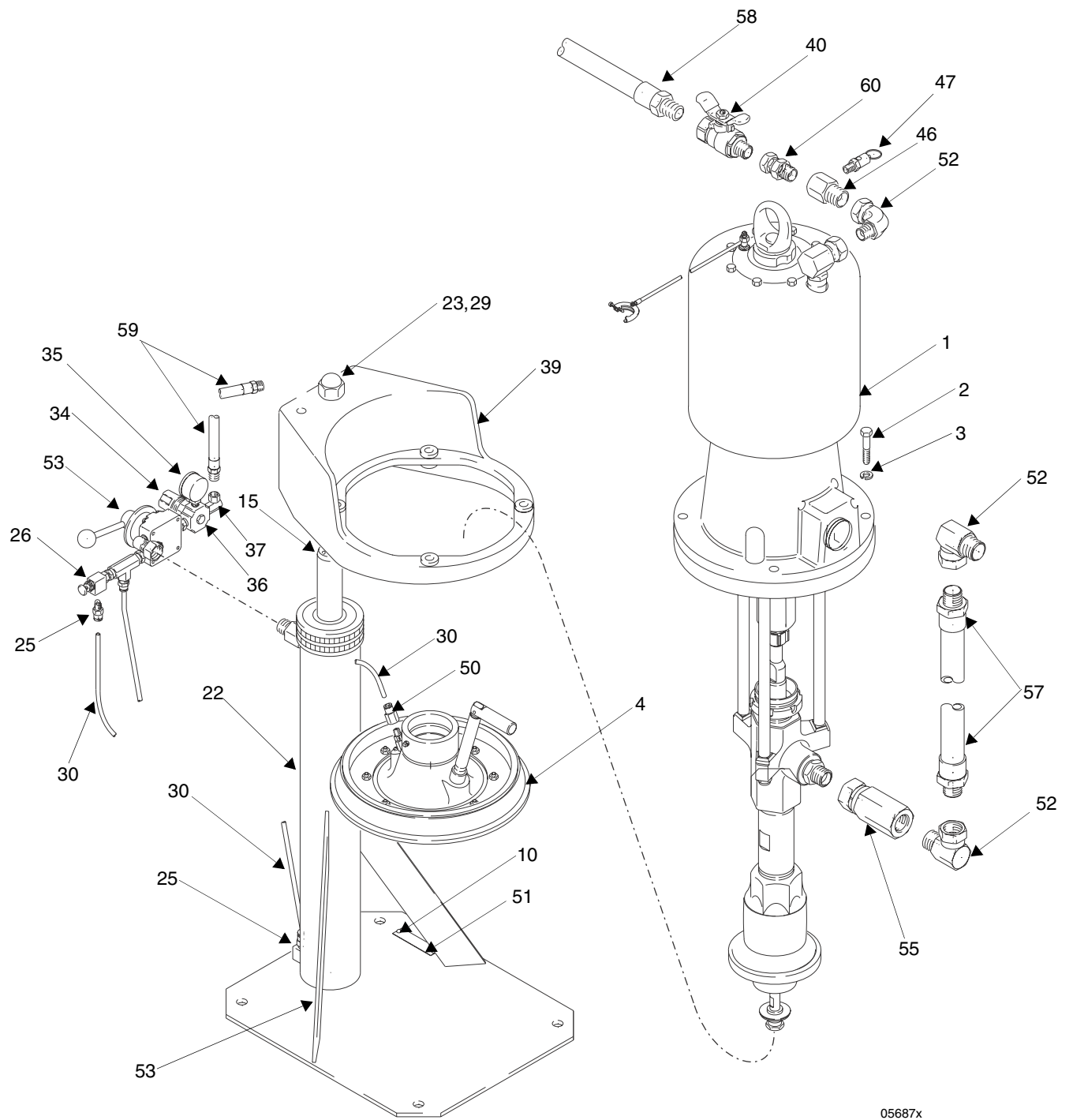

## 23:1 Monark on 5 Gallon Ram

(See Graco Manuals 308026 and 306838)

### Module No. 570142

Ref. No.	Part No.	Description	Qty.	Ref. No.	Part No.	Description	Qty.
1	184147	SHIELD, 5 gallon ram (not shown)	1	50	110318	REGULATOR, air, 1/4 in. npt	1
2	206994	FLUID, TSL 8 oz bottle (not shown)	1	51	104765	PLUG, pipe, headless	1
4	222782	PUMP, Monark	1	52	113896	VALVE, control	1
11	222812	PLATE, wiper, 5 gallon	1	53	166552	CAP, cylinder	1
19	156823	UNION, swivel	1	54	206726	BASE, and cylinder	1
25	155470	UNION, swivel, 90°	1	55	113208	FITTING, tube	2
27	113269	VALVE, ball, vented .500	1	58	190256	CLAMP, support	2
28	155865	UNION, adapter	1	59	100680	SCREW, cap, hex head	4
29	237569	WIRE, assy, 25 ft	1	60	101566	NUT, lock	4
34	156971	NIPPLE, short	1	61	159239	FITTING, nipple, pipe, reducing	1
35	104984	TEE, pipe	1	62	100023	WASHER, flat	4
36	113286	VALVE, safety	1	64	114320	FITTING, connector 1/8 npt(f)	1
37	160701	ELBOW, street	1	65	115901	TRIM, edge, protection	2
41	238925	PISTON, ram, 5 gallon	1	66	100896	FITTING, bushing, pipe	3
42	237562	SUPPORT, pump	1	67	160327	UNION, adapter, 90°	2
43	160107	NUT, cap	1	68	220179	VALVE, check	1
44	101533	WASHER, spring lock	1	69	H45010	HOSE, fluid; nylon; 1/2 in. (13 mm) ID; 1/2 npsm(fbe); 10 ft (3.05 m) long	1
45	190265	SPACER	1				
47	054123	TUBE, nylon 3.7 ft	*				
49	110319	GAUGE, pressure, air, 1/8 in. npt	1	70	214656	HOSE, coupled, 61209, 10 ft	1
				71	109126	HOSE, coupled, 10 ft	1
				73	158491	FITTING, nipple	2

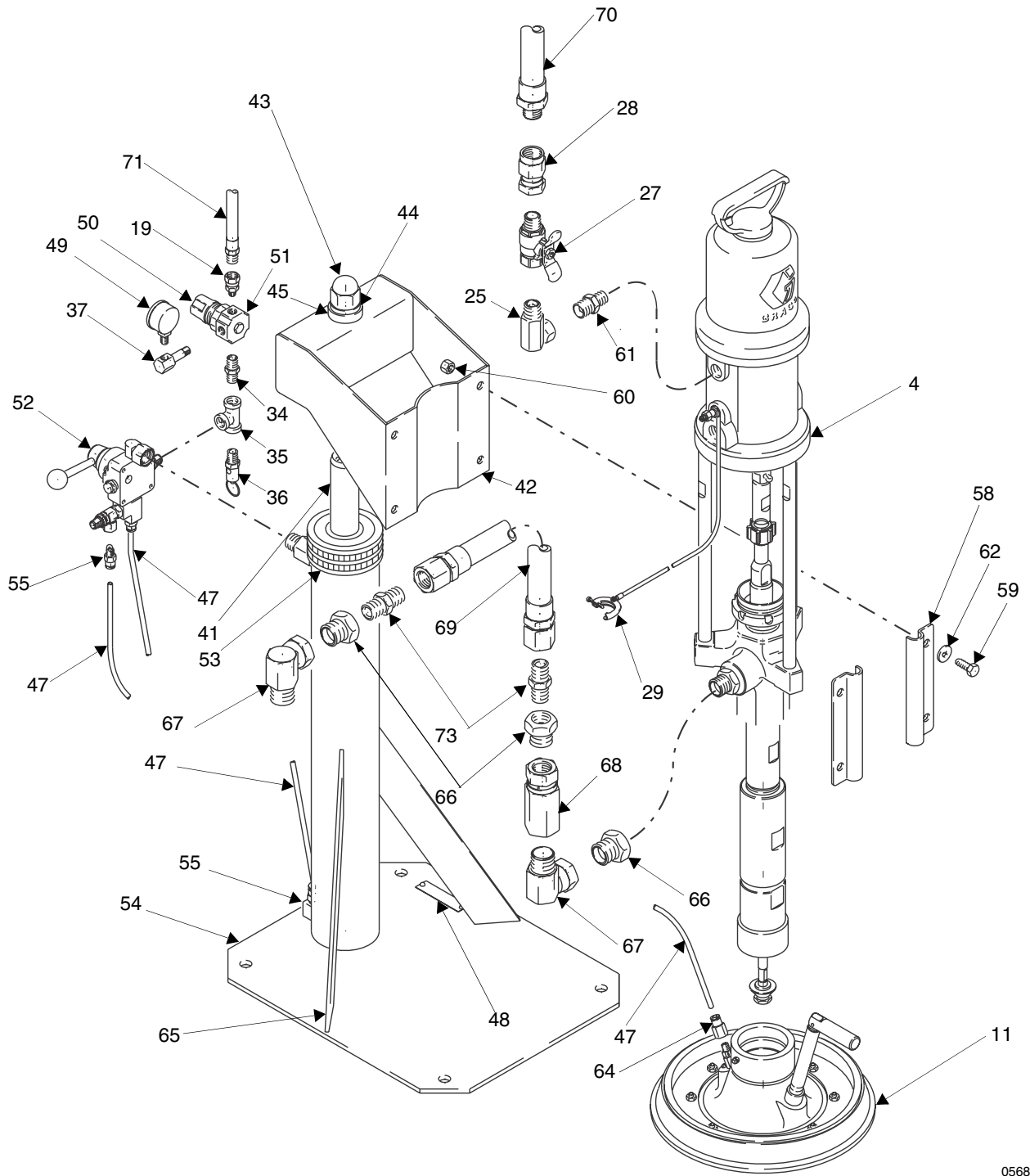

05689C

## 20:1 NXT (700/60) on 55 Gallon Ram

(See Graco Manuals 3A0233 and 312376)

### Module No. 570114

Ref	Part	Description	Qty
2	24C769	RAM, 3" int air, (no pump reg)	1
3	P20LCS	PUMP, 20:1 700/060 l cs s	1
4	255319	PLATE, wiper 55gal epdm	1
5	257299	KIT, d200, 200l, 700-1800	1
6	255392	KIT, mounting, cm lower	1
6a	102637	SCREW	1
6b	276025	CLAMP	1
6c	109495	O-RING	1
7	206537	CLAMP, drum, set of 2 (not shown)	1
9	100132	WASHER, flat (not shown)	4
10	100464	SCREW, lag (not shown)	4
15	292735	ARTWORK, identification	1
17	070408	SEALANT, pipe, sst	1
20	220179	VALVE, check	1
21	160327	FITTING, union adapter, 90 deg	2
22	236422	HOSE, coupled 61220	1
23	100122	NIPPLE, close	2
24	157416	FITTING, swivel, union, 90 deg	1
25	107142	VALVE, ball, vented	1
26	161077	FITTING, union, adapter, straight	1
27	214651	HOSE, coupled 61209	1
28	158212	BUSHING	1
31	237569	WIRE, assy, 25 ft	1
32	070182	TAPE, electrical	1
33	206994	FLUID, tsl 8 oz bottle	1

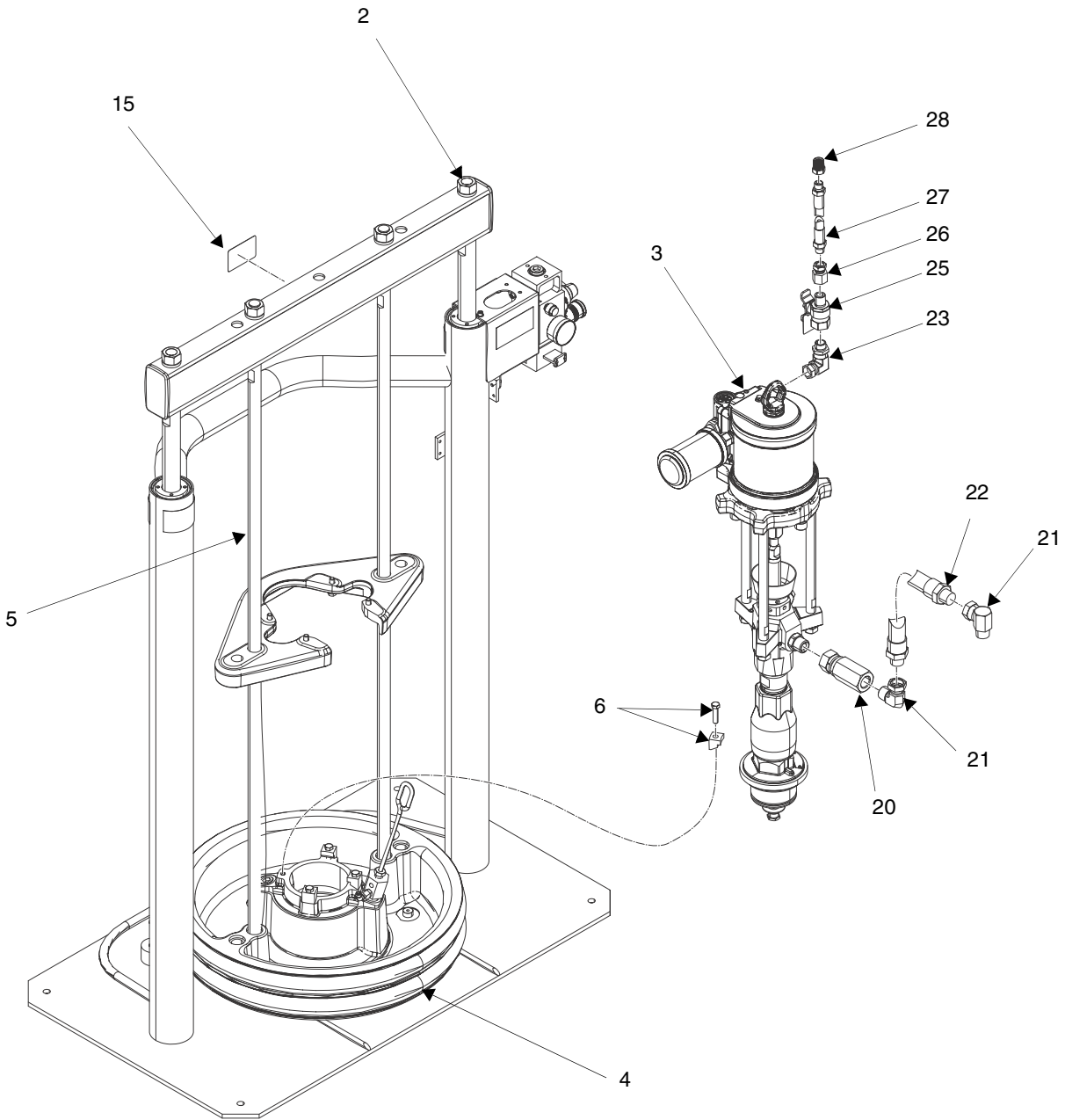

# 40:1 NXT (2200/100) on 55 Gallon Ram

(See Graco Manual 3A0233 and 312376)

## Module No. 965572

Ref	Part	Description	Qty	Ref	Part	Description	Qty
2	24C769	RAM, 3" int air, (no pump reg)	1	21	160327	FITTING, union adapter, 90 deg	3
3	P40LCS	PUMP, 40:1 2200/100 cs sd	1	22	236422	HOSE, coupled, 61220	1
4	255319	PLATE, wiper 55gal epdm	1	24	C20487	FITTING, nipple, hex	1
5	255305	KIT, mounting nxt 3in 55gal	1	25	113332	VALVE, ball, vented, .750	1
6	255392	KIT, mounting, cm lower	1	26	100505	BUSHING, pipe	1
7	206537	CLAMP, drum, set of 2	1	27	214651	HOSE, coupled, 61209	1
9	100132	WASHER, flat	4	28	158212	BUSHING	1
10	100464	SCREW, lag	4	31	237569	WIRE, assy, 25 ft	1
15	292735	ARTWORK, identification	1	32	070182	TAPE, electrical	1
17	070408	SEALANT, pipe, sst	1	33	206994	FLUID, tsl 8 oz bottle	1
20	220179	VALVE, check	1				

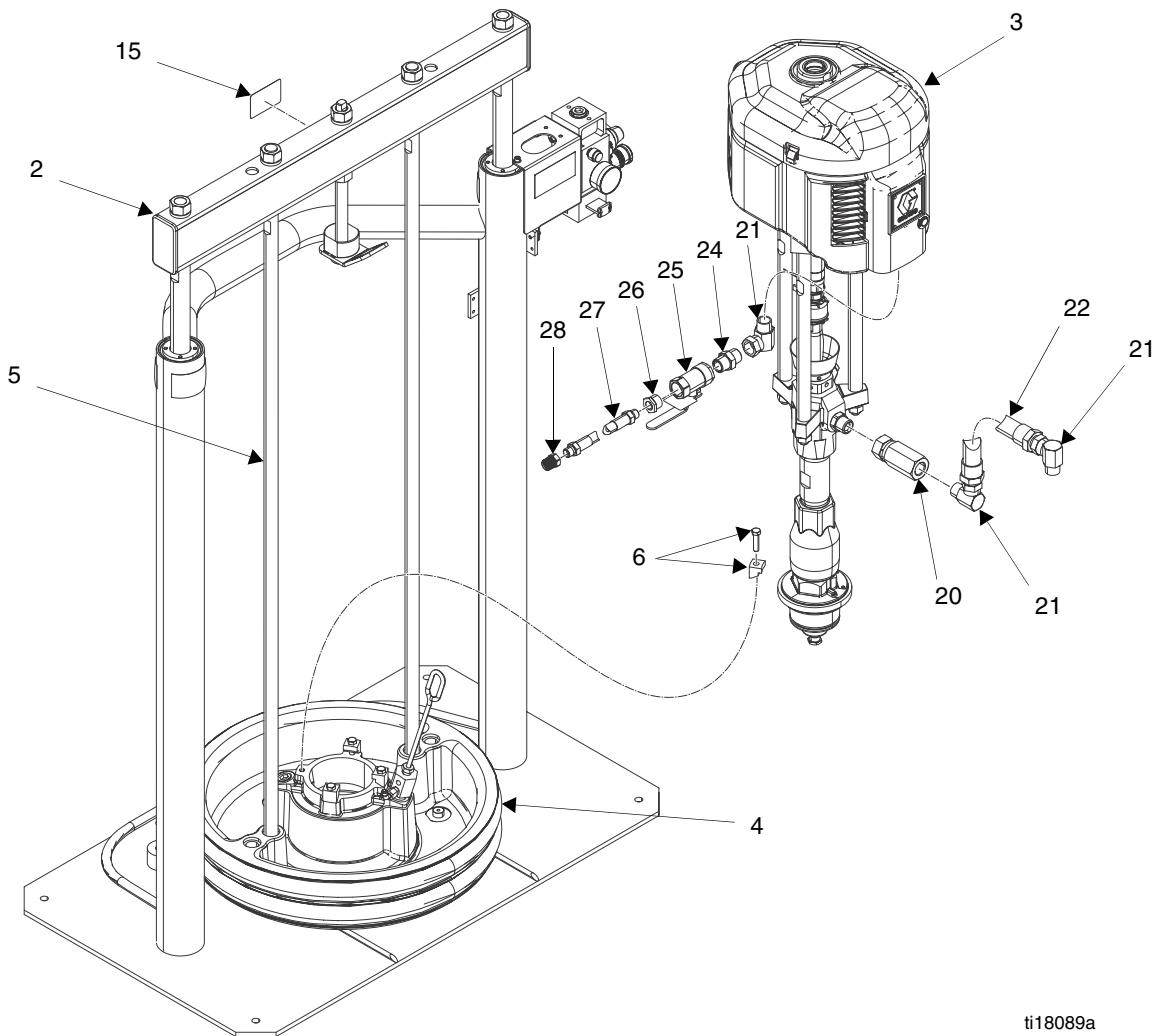

ti18089a

# 23:1 NXT (2200/200) on 55 Gallon Ram

(See Graco Manual 3A0233 and 312376)

## Module No. 570141

Ref	Part	Description	Qty	Ref	Part	Description	Qty
				20	220179	VALVE, check	1
2	24C769	RAM, 3" int air, (no pump reg)	1	21	160327	FITTING, union adapter, 90 deg	3
3	P23LCS	PUMP, 23:1 2200/200 cs sd	1				
4	255319	PLATE, wiper 55gal epdm	1	22	236422	HOSE, coupled, 61220	1
5	255305	KIT, mounting nxt 3in 55gal	1	24	C20487	FITTING, nipple, hex	1
6	255392	KIT, mounting, cm lower	1	25	113332	VALVE, ball, vented, .750	1
7	206537	CLAMP, drum, set of 2	1	26	100505	BUSHING, pipe	1
9	100132	WASHER, flat	4	27	214651	HOSE, coupled, 61209	1
10	100464	SCREW, lag	4	28	158212	BUSHING	1
15	292735	ARTWORK, identification	1	31	237569	WIRE, assy, 25 ft	1
17	070408	SEALANT, pipe, sst	1	32	070182	TAPE, electrical	1
19	158555	FITTING, nipple, 1 x 3/4 npt	1	33	206994	FLUID, tsl 8 oz bottle	1

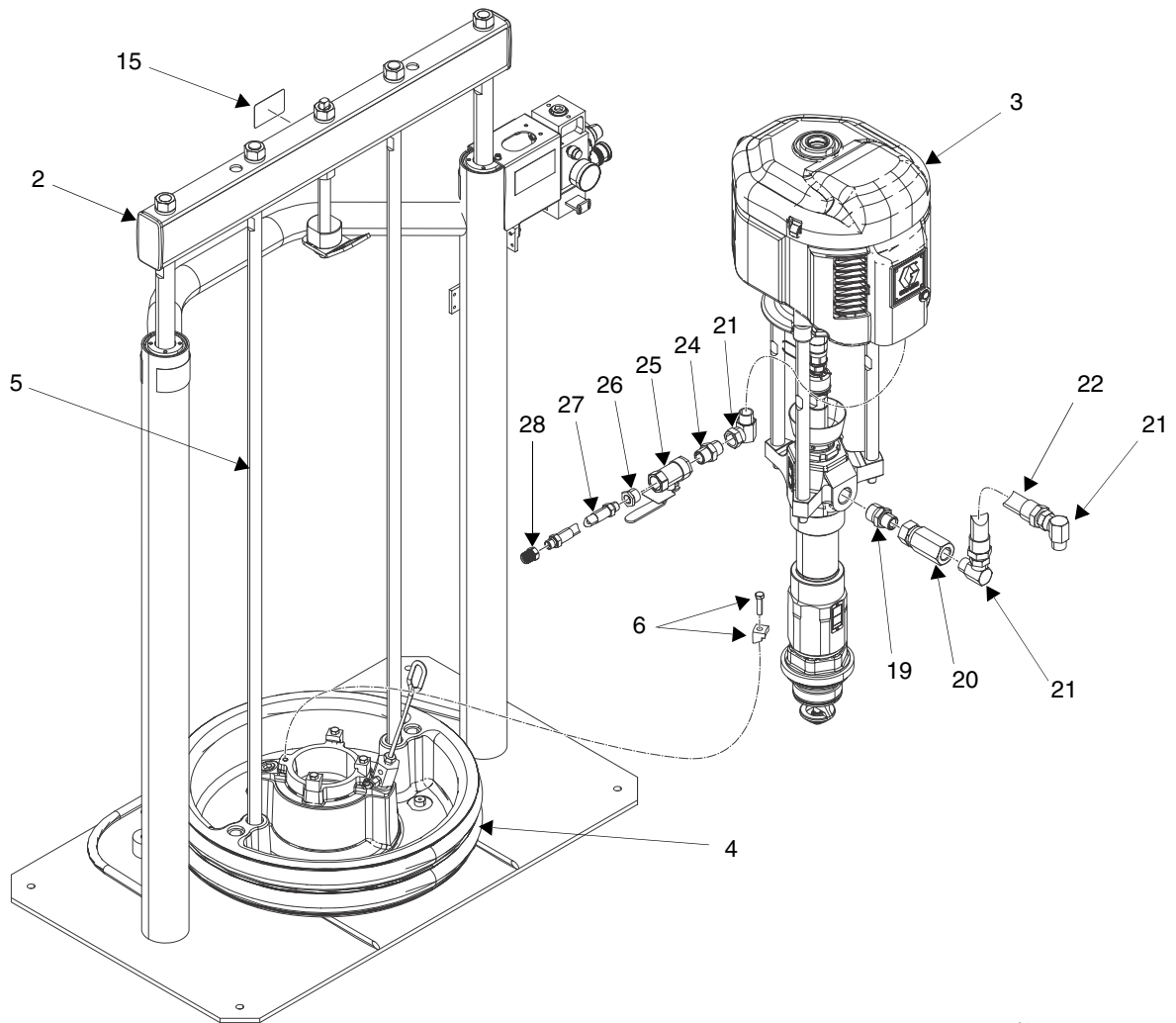

ti18088a

# 20:1 Senator on 55 Gallon Drum

Module No. 570309

Ref. No.	Part No.	Description	Qty.
1	570308	PUMP, 20:1 Senator Dura-Flo 750	1
2	207408	ELEVATOR, stationary	1
3	237579	KIT, repair	1
6	514944	VALVE, needle sst 1/2 MF 6000	1
7	159842	ADAPTER	1
8	100380	BUSHING, pipe	1
9	501764	FITTING, elbow 90° 1 in. npt(f) x 1 in. n	1
10	237309	COVER, drum	1
11	208536	COUPLER, line, air	1
12	158491	FITTING, needle	1
13	237578	SUPPORT, cover assy, sst	1
14	215239	HOSE, coupled 61220	1
22	160327	UNION, adapter, 90°	2
23	160032	NIPPLE	2

Ref. No.	Part No.	Description	Qty.
24	102644	VALVE, ball	2
25	157785	UNION, swivel	1
26	214656	HOSE, coupled 61209, 10 ft	1
28	102471	SCREW, cap hex head	3
29	102021	NUT, lock	3
31	205349	HOSE, coupled 61120, 15 ft	1
32	162449	FITTING, nipple, reducing	2
33	157785	FITTING, union, swivel	1
34	180916	FITTING, tee 3/4(m) run x 1/4(f) branch	1
35	214037	VALVE, ball	3
36	109126	HOSE, coupled, 10 ft	1
38	187614	NUT, jam	1
39	159446	GASKET, vellumoid	1
40	15C321	PLATE, cover	1
41	100896	FITTING, bushing, pipe	1
42	15C322	RETAINER, siphon tube	1
43	190999	NUT, retainer	1
44	238161	TUBE, siphon, hd agitator	1
45	113218	VALVE, ball, vented, .750	1

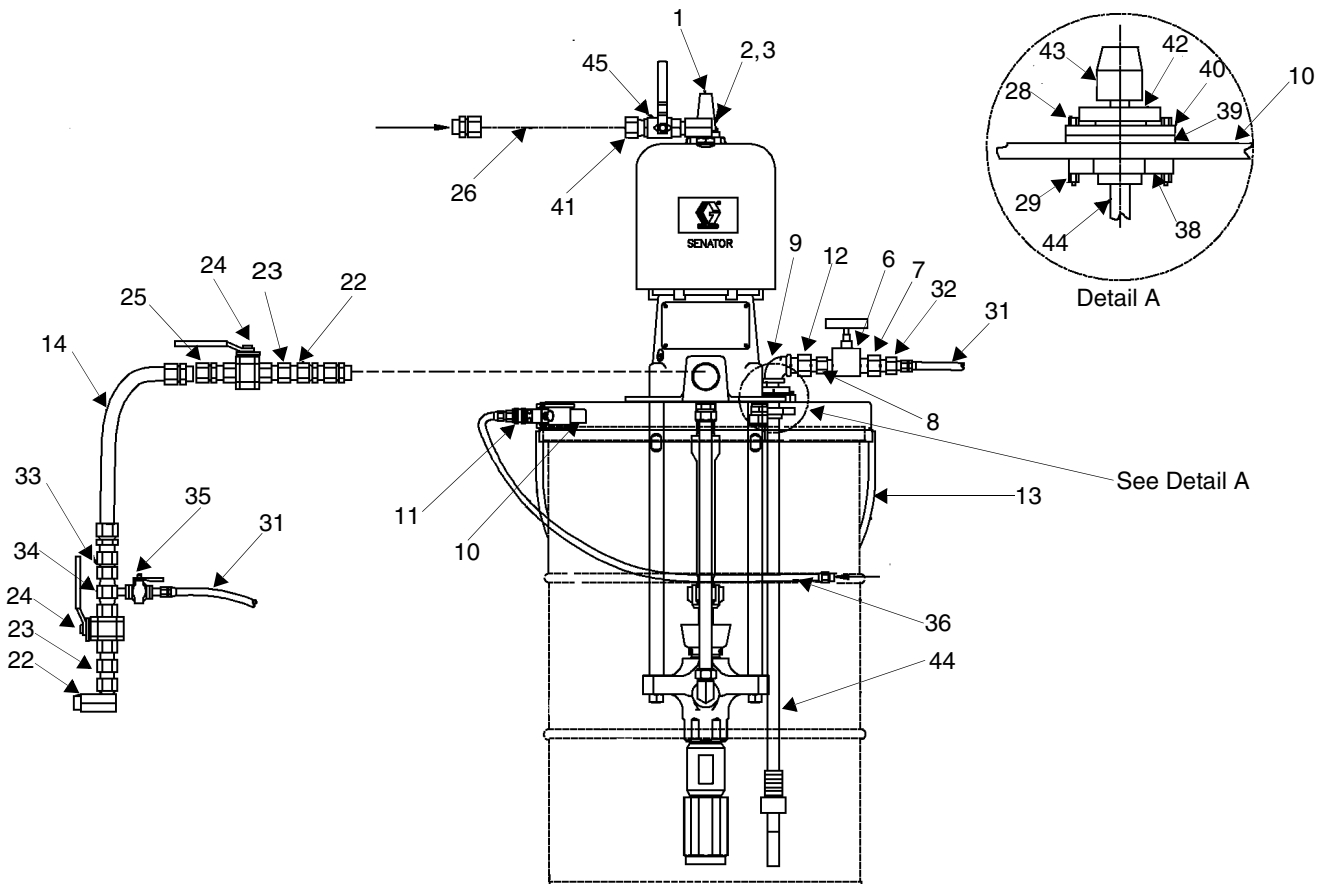

# 9:1 DynaMite on 1 Gallon Can Ram

## Module No. 570249

Ref. No.	Part No.	Description	Qty.	Ref. No.	Part No.	Description	Qty.
1	235871	PUMP, extruder, sst, 190	1	8	C24332	BOLT, "U"	2
2	217298	BRACKET, mounting	1	9	100615	BUSHING, hex steel	1
3	514518	HOSE, coupled 3/16 in. x 3 ft	1	10	101885	SCREW, cap sch	2
4	109125	HOSE, coupled 72 in.	1	11	102040	NUT, lock, hex	2
5	224908	INDUCTOR, assy, 1 gal.	1	12	100086	WASHER, plain	1
6	156823	UNION, swivel	2	13	155541	UNION, swivel, 90°	1
7	156971	NIPPLE, short	2	14	100206	BUSHING, pipe	1

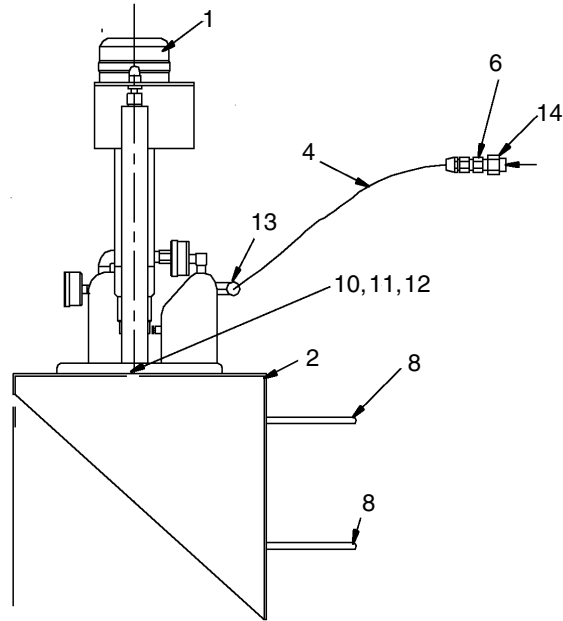
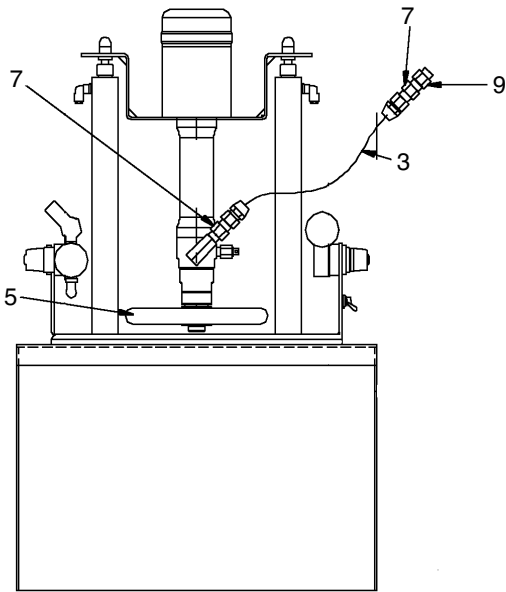

# 10 Gallon Press Tank with 15:1 Booster

Module No. 570037

Ref. No.	Part No.	Description	Qty.
2	101946	PIN, cotter, sst	1
3	102325	ELBOW, 90°	1
5	156082	PACKING, o-ring	1
6	156823	UNION, swivel	1
7	157785	UNION, swivel	2
8	217296	FRAME, pump	1
9	167682	ROD, tie	3
10	207352	MOTOR, air, pres	1
11	207370	ROD, connecting	1
12	215930	PUMP, displ, recip	1
13	221170	HOSE, coupled, 061260, 3 ft	1
14	236150	TANK, high pressure 10 gallon	1

Ref. No.	Part No.	Description	Qty.
15	236662	AGITATOR, heavy duty, 10 gallon	1
16	236677	KIT, repair	1
17	501603	VALVE, check 1/2 in. npt mbe sst tf	1
18	512484	VALVE, ball, sst	1
19	620198	PLATE, mounting	1
21	100101	SCREW, cap, hex head	4
22	100133	WASHER, lock	4
23	100131	NUT, full hex	4
24	100016	WASHER, lock	2
25	100022	SCREW, cap, hex head	2
26	150707	PLATE, designation	1
27	H45010	HOSE, fluid; nylon; 1/2 in. (13 mm) ID; 1/2 npsm(fbe); 10 ft (3.05 m) long	1
28	100896	FITTING, bushing, pipe	1
29	160327	UNION, adapter, 90°	1
30	214656	HOSE, coupled, 61209, 10 ft	1
31	109126	HOSE, coupled, 10 ft	1
32	158491	FITTING, nipple	3
33	107142	VALVE, ball, vented	1

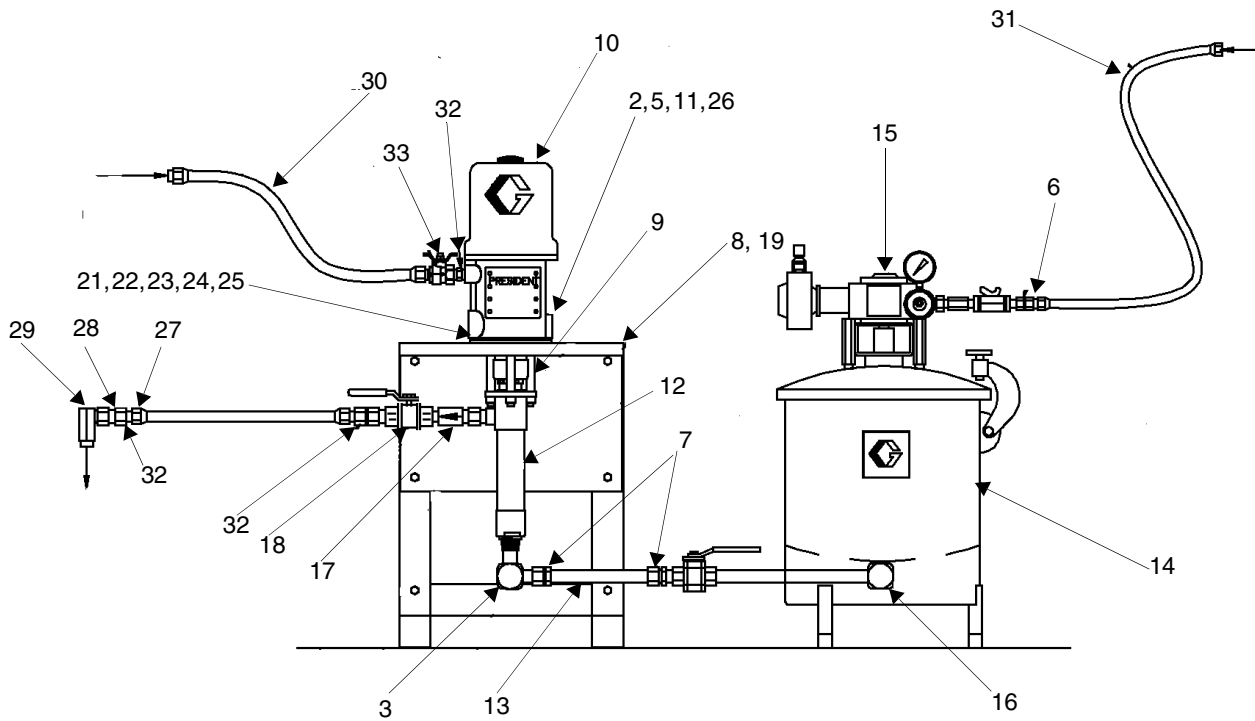

# 10:1 President 5 Gallon Pail Cover

## Module No. 570264

Ref. No.	Part No.	Description	Qty.	Ref. No.	Part No.	Description	Qty.
1	903295	PUMP, 10:1 President, sst	1	6	165516	PACKING, o-ring	1
3	100035	SCREW, machine, panhead	1	7	101962	SCREW, set sch	2
4	206755	CHAIN	1	8	100220	SCREW, thumb	3
5	165096	PLUG	1				

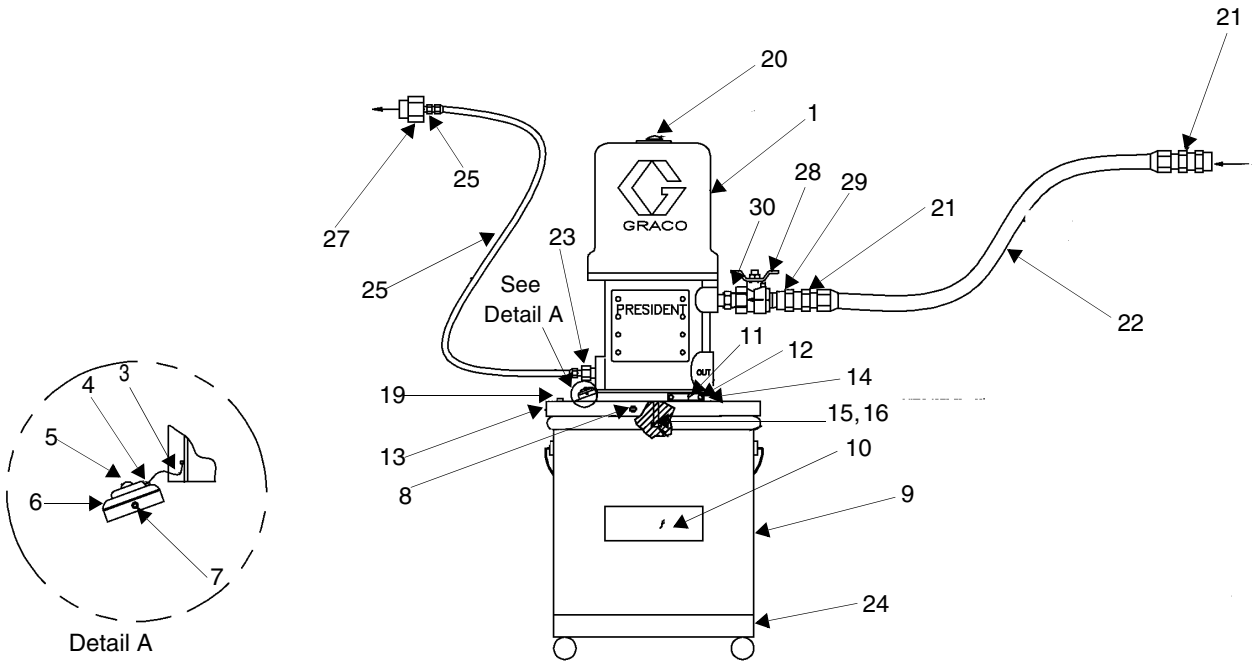

## Mix Kit Selection

### Cartridge Fill Medium Viscosity Wide Ratio

#### Module No. 570248

Ref. No.	Part No.	Description	Qty.	Ref. No.	Part No.	Description	Qty.
4	626748	BRACKET, mount disp valv C24342	1	47	597151	FITTING, elbow	6
5	552204	ACTUATOR, air, 8900 metered shot	1	48	552211	VALVE, pulse pneumatic	2
6	C30021	BOLT, u	1	49	593538	VALVE, shuttle 1/8 npt(f)	1
10	504327	HOSE, nylon 3/4 in. id	4	50	503028	VALVE, air, push-pull	1
11	504621	COUPLING, hose	4	51	104631	KIT, accessory	1
12	166590	ELBOW, street	2	52	100730	BUSHING	2
13	160327	UNION, adapter, 90°	2	53	104984	TEE, pipe	2
14	175013	NIPPLE, pipe	1	54	C19391	FITTING, elbow 1/4 npt(m) x 1/4 od tube	4
15	512442	HOSE, bulk 1/2 in. nylon 3500 psi	8	56	512420	FITTING, cross steel 3/8 npt	1
16	503917	COUPLING, hose 1/2 ft npt(m) x 1/2, 3903	8	57	100195	NIPPLE, pipe	1
17	105281	UNION, swivel, 90°	1	58	103656	FITTING, pipe, hex	2
18	512616	HOSE, PTFE 1/4 x 18 in. 1/4 npsm	1	59	599433	FITTING, elbow, male	1
19	500517	FITTING, tee 3/4 in. npt	1	60	501014	ACTUATOR, air 1/8 npt(f)	2
20	158683	FITTING, elbow 3/4 in. npt	4	63	114372	MIXER, static, 1/2 npt	2
24	100896	FITTING, bushing, pipe	5	64	158581	COUPLING, hex	2
25	155470	UNION, swivel, 90°	1	65	948081	MIXER, tri-core 1/2(m) x 1/2(f)	1
26	156684	UNION, adapter,	2	66	159153	UNION, swivel	1
27	100840	ELBOW, street	2	67	690270	ADAPTER, luer lock 1/4 in. npt	2
32	156971	NIPPLE, short	4	68	112012	NOZZLE, needle	2
33	626758	MANIFOLD, block 8900 meter, shot	1	69	112019	NOZZLE, needle	2
34	626757	BLOCK, check 8900 metered shot	1	70	205324	HOSE, coupled, 61120, 1 ft	1
35	C26088	VALVE, cone extension	1	71	164672	ADAPTER	2
36	C26086	STOP, cone, assembly	1	73	159239	FITTING, nipple, pipe, reducing	1
37	103374	SCREW, machine, rdh	4	74	552208	VALVE, ball 3-way	1
38	105192	SCREW, cap, hex head	1	75	100206	BUSHING, pipe	2
40	C24017	ROD, trip, valve	1	76	552205	MIXER, pipe, sst 1/4-4.2 in. 12 el	2
41	C20068	PIN, spring	2	77	626760	MANIFOLD, ratio check 8900 shot	1
42	C24018	COLLAR, stop	2	79	102646	VALVE, ball	1
43	C24020	COLLAR, clamp	1	80	156877	NIPPLE, long	1
44	120753	FITTING, elbow, male, 90°	4	81	112013	NOZZLE, needle	2
45	513066	TUBE, 3/8 ft OD nylon	3	82	112014	NOZZLE, needle	2
46	C12509	TUBE, nylon	20	83	112015	NOZZLE, needle	2
				84	112020	NOZZLE, needle	2
				85	112021	NOZZLE, needle	2
				86	112022	NOZZLE, needle	2
				87	162449	FITTING, nipple, reducing	2
				88	100403	PLUG, pipe	2
				90	158491	FITTING, nipple	1

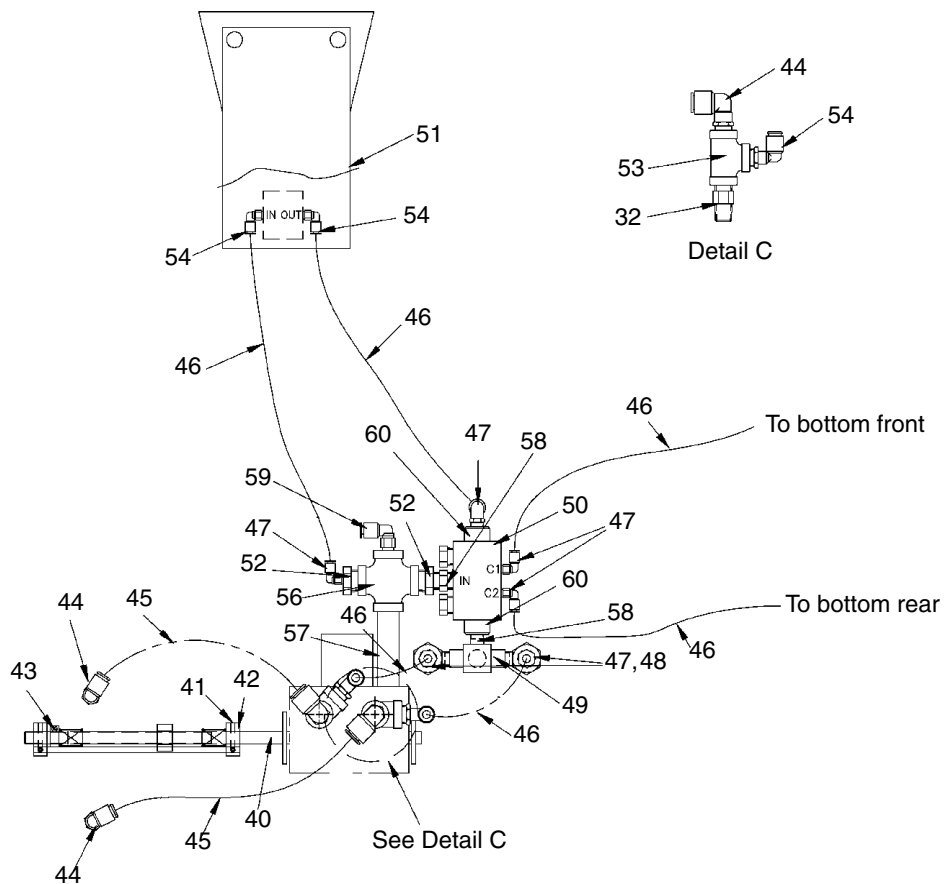
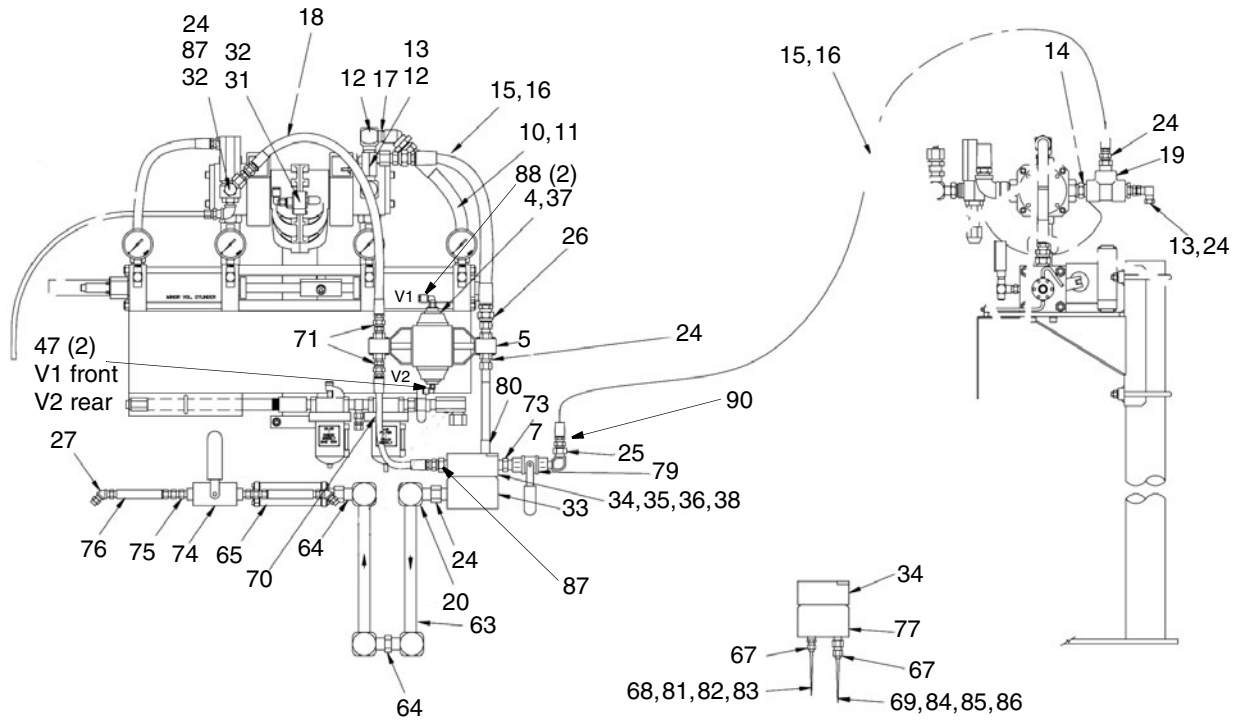

## Cartridge Fill High Viscosity Wide Ratio

### Module No. 570318

Ref. No.	Part No.	Description	Qty.	Ref. No.	Part No.	Description	Qty.
1	552204	ACTUATOR, air, 8900 metered shot	1	29	C12509	TUBE, nylon	30
2	626748	BRACKET, mount disp valv C24342	1	30	503028	VALVE, air, push-pull	1
3	103374	SCREW, machine, rdh	4	31	157191	FITTING, adapter	4
4	100896	FITTING, bushing, pipe	1	32	596832	FITTING, tee, tube	1
5	156877	NIPPLE, long	1	33	501014	ACTUATOR, air 1/8 npt(f)	2
6	105192	SCREW, cap, hex head	1	34	103656	FITTING, pipe, hex	1
7	626757	BLOCK, check 8900 metered shot	1	35	593538	VALVE, shuttle 1/8 npt(f)	1
8	626758	MANIFOLD, block 8900 meter shot	1	36	552211	VALVE, pulse, pneumatic	2
9	166590	ELBOW, street	1	37	C19391	FITTING, elbow 1/4 npt(m) x 1/4 od tube	5
10	513375	MIXER, pipe sst 3/4-16.4 in. 2 el	2	38	104631	VALVE, foot	1
11	100349	FITTING, elbow	3	40	626760	MANIFOLD, ratio check 8900 shot	1
12	160032	NIPPLE	1	42	H55033	HOSE, bulk 1/2 in. nylon 5600 psi	6
13	552208	VALVE, ball 3-way	1	47	100133	WASHER, lock	2
14	100206	BUSHING, pipe	2	48	100131	NUT, full hex	2
15	552205	MIXER, pipe sst 1/4-4.2 in. 24 el	2	50	104172	FITTING, tube	2
16	100840	ELBOW, street	4	51	512231	CONNECTOR, 1/4 od x 1/8 in. npt(f)	2
17	157350	ADAPTER, 3/8 npt x 1/4 npt	2	54	156971	NIPPLE, short	5
18	205324	HOSE, coupled, 61120, 1 ft	1	55	233415	KIT, accessory, ratio check	1
19	162449	FITTING, nipple, reducing	1	58	157785	UNION, swivel	1
20	100040	PLUG, pipe	1	60	160327	UNION, adapter, 90°	2
21	155699	ELBOW, street	1	61	166466	TEE, pipe, female	1
22	159239	FITTING, nipple, pipe, reducing	1	63	104984	TEE, pipe	2
23	102646	VALVE, ball	1	64	120753	FITTING, elbow, male, 90°	2
24	158491	FITTING, nipple, 1/2 npt	1	65	100003	SCREW, cap, hex head	2
25	C26088	VALVE, cone extension	1	66	100176	BUSHING, hex	1
26	C26086	STOP, cone assembly	1	68	512616	HOSE, coupled 61120, 1.5 ft	1
27	151249	NIPPLE, pipe	1	69	100615	BUSHING, hex	1
28	112698	ELBOW, male, swivel	1				

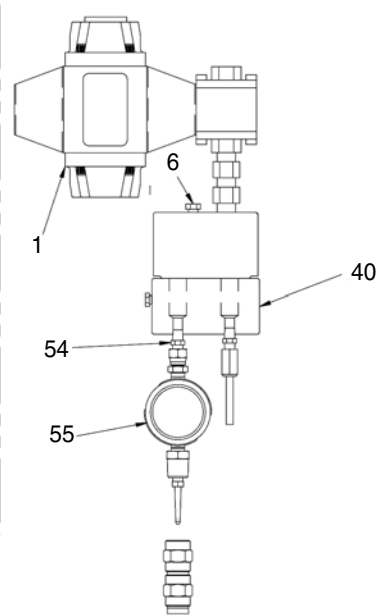
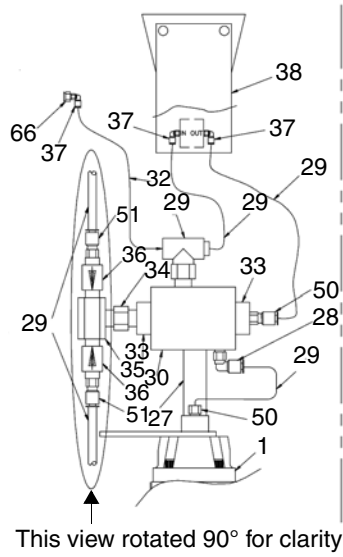
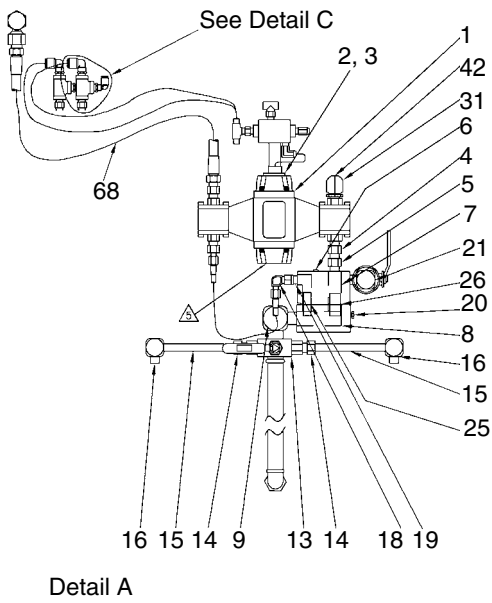
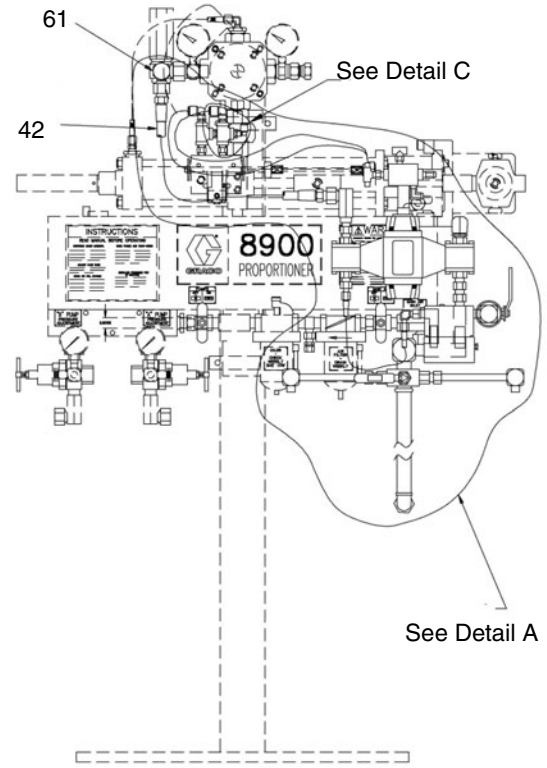
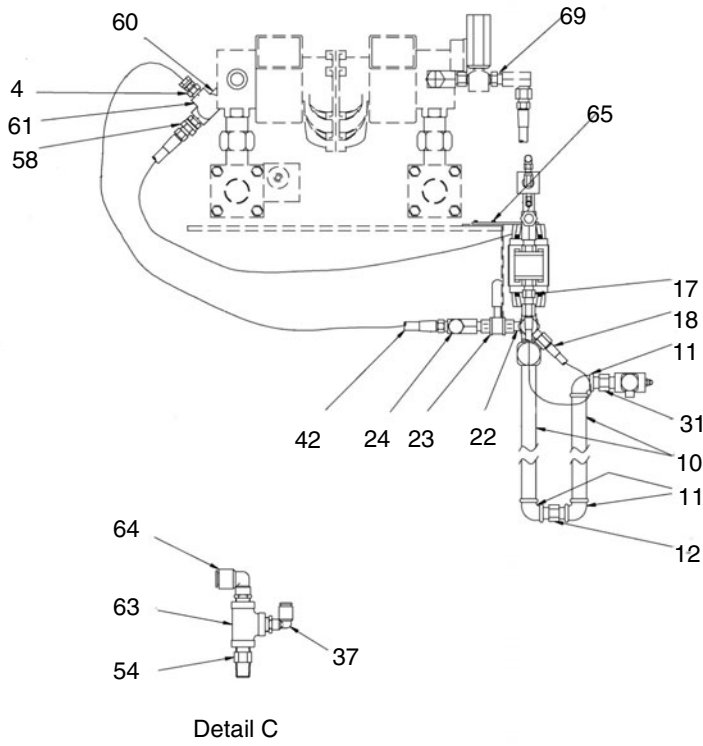

## Brush Grade High Viscosity Wide Ratio

### Module No. 570358

Ref. No.	Part No.	Description	Qty.	Ref. No.	Part No.	Description	Qty.
1	159841	ADAPTER	3	58	103656	FITTING, pipe, hex	4
2	114112	FITTING, connector, female	1	59	599433	FITTING, elbow, male	1
3	100030	BUSHING	1	60	501014	ACTUATOR, air 1/8 npt(f)	3
4	626748	BRACKET, mount disp valv C24342	1	63	114372	MIXER, static, 1/2 npt	2
5	552204	ACTUATOR, air 8900 metered shot	1	54	158581	COUPLING, hex	2
6	C30021	BOLT, u	2	65	948081	MIXER, tri-core 1/2(m) x 1/2(f)	1
7	155699	ELBOW, street	1	66	159153	UNION, swivel	1
8	100615	BUSHING, hex steel	1	67	690270	ADAPTER, luer lock 1/4 in. npt	2
9	159801	UNION, swivel, 90°	1	68	112012	NOZZLE, needle	2
10	504327	HOSE, nylon 3/4 in. id	4	69	112019	NOZZLE, needle	2
11	504621	COUPLING, hose	4	70	205324	HOSE, coupled, 61120, 1 ft	1
12	166590	ELBOW, street	2	71	164672	ADAPTER	2
13	160327	UNION,	2	72	162449	FITTING, nipple, reducing	1
14	175013	NIPPLE, pipe	1	73	159239	FITTING, nipple, pipe, reducing	1
15	512442	HOSE, bulk 1/2 in. nylon 3500 psi	8	74	552208	VALVE, ball, 3-way	1
16	503917	COUPLINE, hose, 1/2 npt(m) x 1/2, 3903	8	75	100206	BUSHING, pipe	3
17	105281	UNION, swivel 45°	1	76	552205	MIXER, pipe sst 1/4-4.2 in. 12 el	2
18	512616	HOSE, PTFE 1/4 x 18 ft 1/4 npsm	1	77	626760	MANIFOLD, ratio check 8900 shot	1
19	500517	FITTING, tee 3/4 in. npt	1	79	102646	VALVE, ball	1
20	158683	FITTING, elbow, 90°	5	80	156877	NIPPLE, long	1
24	100896	FITTING, bushing, pipe	5	82	100175	COUPLING, pipe	2
25	155470	UNION, swivel, 90°	1	83	511871	MIXER, static	2
26	156684	UNION, adapter	2	84	108233	VALVE, needle	1
27	100840	ELBOW, street	4	85	156823	UNION, swivel	1
31	512912	MUFFLER, polyethylene 1/2 npt	2	86	965766	VALVE, 1k-ul, machine mount	1
32	156971	NIPPLE, short	5	90	101353	NIPPLE, pipe	1
33	626758	MANIFOLD, block 8900 meter shot	1	91	157416	UNION, swivel, 90°	1
34	626757	BLOCK, check 8900 metered shot	1	92	158491	FITTING, nipple	1
35	C26088	VALVE, cone extension	1	93	501459	VALVE, toggle, air	1
36	C26086	STOP, cone, assembly	1	94	110460	FITTING, el male swivel, 10-32x5/32	1
37	133374	SCREW, machine, rdh	4	95	598140	FITTING, elbow 5/32t x 1/8 in. npt(m)	1
38	105192	SCREW, cap, hex head	1	96	510220	VALVE, air 4-way spring 1/4 npt	1
40	C24017	ROD, trip, valve	1	97	104165	FITTING, tube	2
41	C20068	PIN, spring	2	98	164815	FITTING, adapter, tee	1
42	C24018	COLLAR, stop	2	99	503279	FITTING, union straight 1/8 in. mx f sw	1
43	C24020	COLLAR, clamp	1	100	112013	NOZZLE, needle	1
44	120753	FITTING, elbow, male, 90°	6	101	112014	NOZZLE, needle	2
45	513066	TUBE, 3/8 in. OD nylon	6	102	112015	NOZZLE, needle	2
46	C12509	TUBE, nylon	20	103	112020	NOZZLE, needle	2
47	597151	FITTING, elbow	11	104	112021	NOZZLE, needle	2
48	552211	VALVE, pulse pneumatic	2	105	112022	NOZZLE, needle	2
49	593538	VALVE, shuttle 1/8 npt(f)	2				
50	503028	VALVE, air, push-pull	1				
51	212099	KIT, accessory	1				
52	100730	BUSHING	2				
53	104984	TEE, pipe	2				
54	C19391	FITTING, elbow 1/4 npt(m) x 1/4 od tube	5				
56	512420	FITTING, cross steel 3/8 npt(f)	1				
57	100195	NIPPLE, pipe	1				



# MD2 20 ft Automatic

(See Graco Manual 312185)

## Wide Ratio Module No. 24H258

## Close Ratio Module No. 24H259

Ref. No.	Part No.	Description	Qty.	Ref. No.	Part No.	Description	Qty.
1	255182	VALVE, MD2, 1:1, hard seats (24H258)	1	13	617467	BUSHING, hex reducing 3/4 x 12	1
	255180	VALVE, MD2, 10:1, hard (24H259)	1	14	160327	UNION, adapter, 90°	2
2	15K688	NUT, retainer, ratio check	2	15	189018	SWIVEL, 5800 psi	1
3	LC0079	MIXER, static, 3/8 x 24	50	16	598140	FITTING, elbow 5/32T x 1/8 in. npt(m)	4
4	157350	ADAPTER, 3/8 npt x 1/4 npt	1	17	514607	TUBE, nylon 2.5mm id red	60
5	122969	FITTING, elbow, 1/4 npt x SAE 06 (9/16-18 thread)	2	18	552071	SLEEVE, protective	25
8	H52525	HOSE, fluid; nylon; 1/2 in. (13 mm) ID; 3/8 npsm(fbe); 25 ft (7.6 m) long	1	19	156971	NIPPLE, short, 1/4-18 npt	2
9	503536	FITTING, nipple, reducing, mod.	1	21	947937	VALVE, injector #40 1/4 npt	1
10	207946	SWIVEL, straight	1	23	155570	SWIVEL, union	1
11	552026	HOSE, PTFE/sst-10 hp 20 ft	1	24	C19008	FITTING, adapter, swivel	1
12	16G003	FITTING, adapter	2				

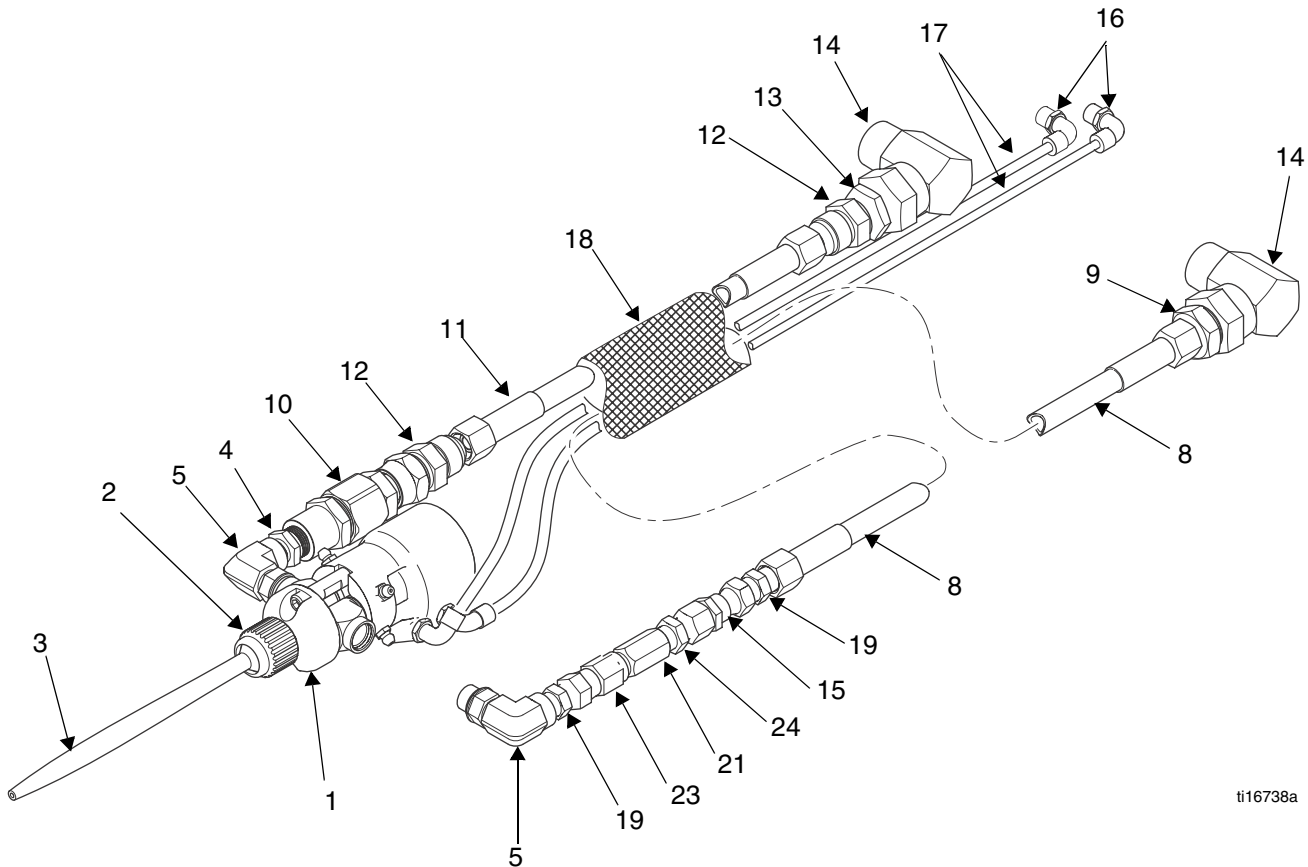

ti16738a

# MD2 20 ft Hand Gun

Wide Ratio Module No. 24H260

Close Ratio Module No. 24H261

Ref.			Ref.				
No.	Part No.	Description	Qty.	No.	Part No.	Description	Qty.
1	255445	VALVE, MD2, 10:1, hard seats, gun, air (24H260)	1	9	157350	ADAPTER, 3/8 npt x 1/4 npt	1
	255442	VALVE, MD2, 1:1, hard seats, gun, air (24H261)	1	10	207946	SWIVEL, straight	1
2	15K688	NUT, retainer, ratio check	2	11	H45010	HOSE, coupled; 1/2 in. (13 mm) ID; 1/2-14 npsm; 50 ft (15.2 m) long	2
3	LC0080	MIXER, static, 3/8 x 36	50	12	158491	FITTING, nipple	3
5	122969	FITTING, elbow, 1/4 npt x SAE 06 (9/16-18 thread)	2	13	617467	BUSHING, hex reducing 3/4 x 12	1
6	501867	VALVE, check	2	14	160327	UNION, adapter, 90°	2
7	205324	HOSE, coupled, 61120, 1 ft	1	15	503536	FITTING, nipple, reducing, mod.	1
8	H52525	HOSE, fluid nylon; 1/4 in. (6.4 mm) ID; 1/4 npsm(fbe); 25 ft (7.6 m) long	1	16	598140	FITTING, elbow 5/32t x 1/8 in. npt(m)	2
				17	514607	TUBE, nylon 2.5mm id red	30
				18	552071	SLEEVE, protective	25
				19	189018	SWIVEL, 5800 psi	2

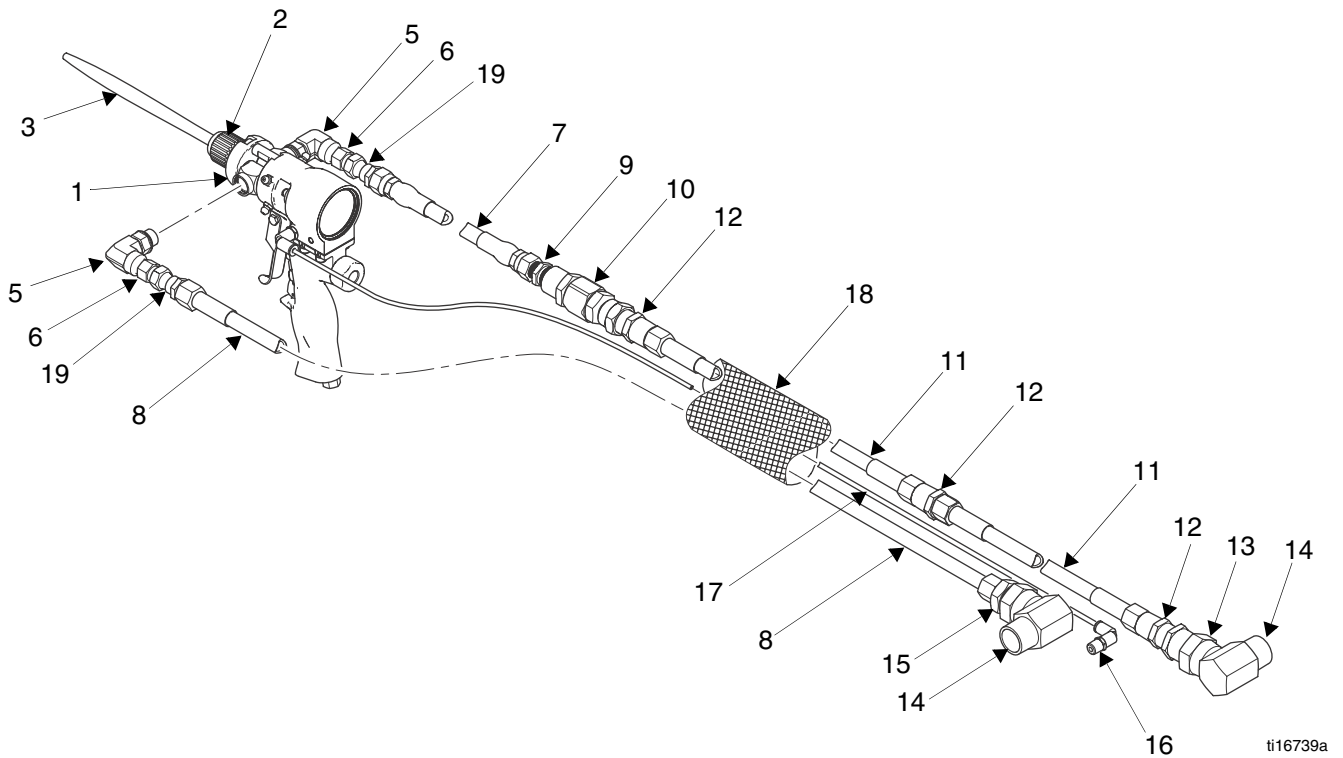

# MD2 15 ft Hand Gun Wide Ratio Moisture Lock

Module No. 24H243

Ref. No.	Part No.	Description	Qty.	Ref. No.	Part No.	Description	Qty.
1	255445	VALVE, MD2, 10:1, hard seats, gun, air	1	12	156172	FITTING, union, swivel	1
2	189018	SWIVEL, 5800 psi	1	13	214925	SWIVEL, hose	2
4	162453	NIPPLE, (1/4 nps(m) x 1/4 npt)	4	14	160327	UNION, adapter, 90°	1
5	122969	FITTING, elbow, 1/4 npt x SAE 06 (9/16-18 thread)	2	15	503536	FITTING, nipple, reducing, mod.	2
6	501684	VALVE, check	1	16	598140	FITTING, elbow 5/32t x 1/8 in. npt(m)	32
7	235905	HOSE, coupled, 2.5 ft	1	17	514607	TUBE, nylon 2.5mm id red	15
8	514428	HOSE, 1/4 in. PTFE x 10 ft	2	18	552071	SLEEVE, protective	1
9	162024	COUPLING	1	19	LC0057	MIXER, shroud, 1/4-24	1
10	161490	COUPLING, reducing	1	20	155570	UNION, swivel	1
11	512247	HOSE, 5/8 PTFE 7.5 ft 3/4 npt(m)	2	21	947937	VALVE, injector #40 1/4 in. not	1
				22	100730	BUSHING	1

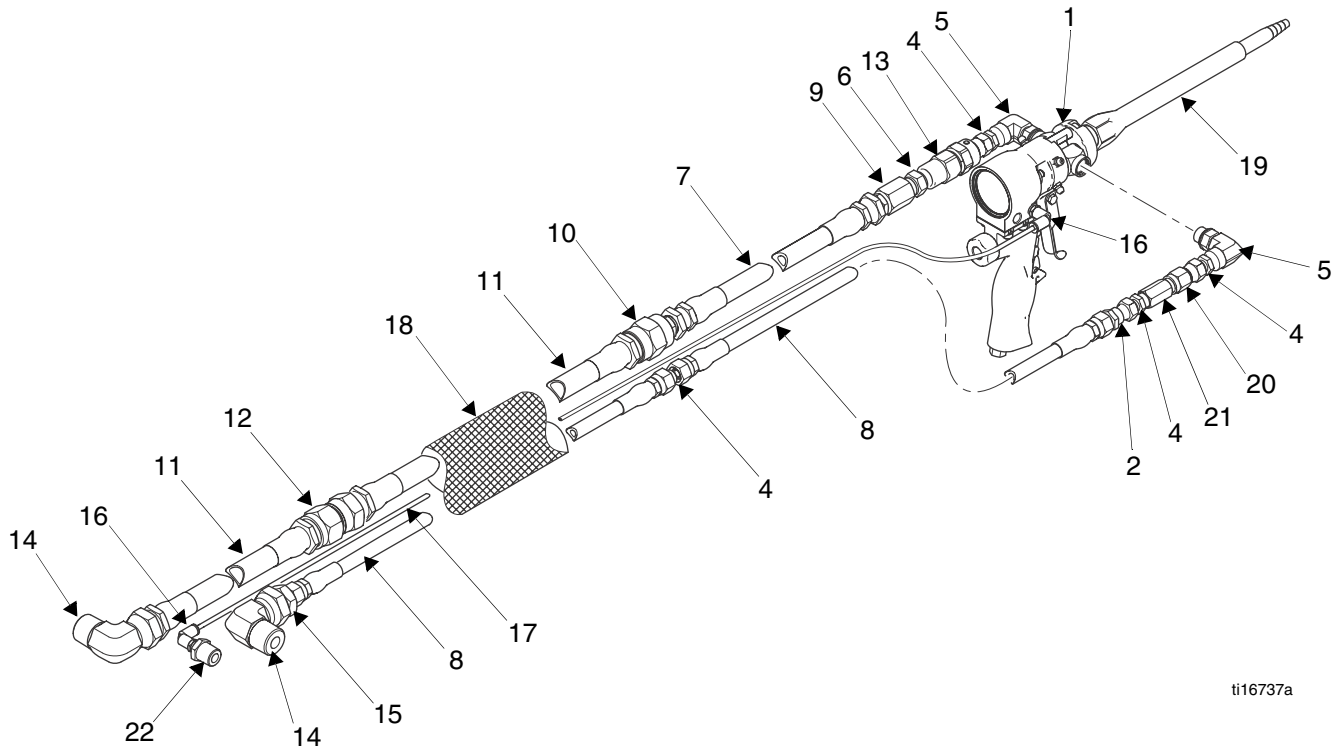

ti16737a

# High Volume Static Mix Manifold

Module No. 570391

Ref. No.	Part No.	Description	Qty.	Ref. No.	Part No.	Description	Qty.
1	157785	UNION, swivel	2	7	501392	FITTING, cross 3/4 in. npt cs 2000 psi	1
2	512151	VALVE, ball	2	8	100896	FITTING, bushing, pipe	1
3	175013	NIPPLE, pipe	4	9	156823	UNION, swivel	1
4	220179	VALVE, check	2	10	214037	VALVE, ball	1
5	160327	UNION, adapter, 90°	2	11	204938	HOSE, coupled, 61120, 25 ft	1
6	100615	BUSHING, hex steel	1				

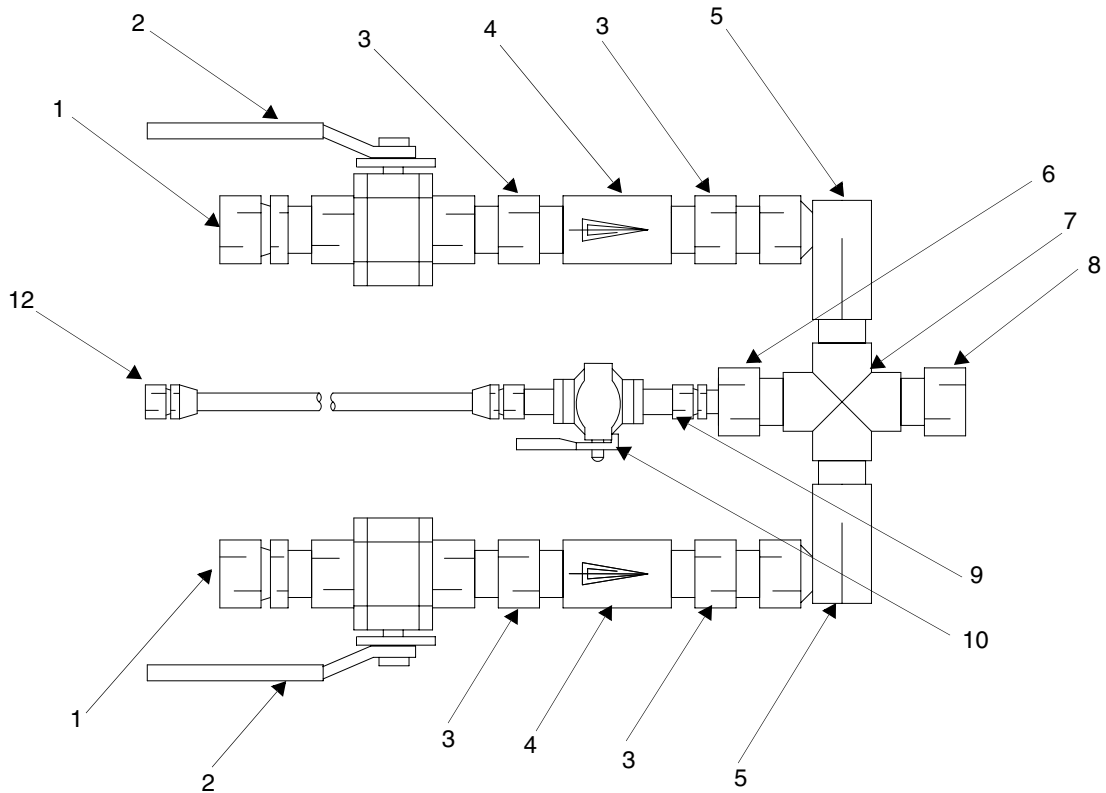

TI3261A

# High Volume Static Mix Kit with Pump Pilots

Module No. 570263

Ref. No.	Part No.	Description	Qty.	Ref. No.	Part No.	Description	Qty.
1	504704	FITTING, nipple, hex	1	15	158586	FITTING, bushing	3
2	512152	VALVE, ball 2000 psi 1 in. npt(f)	1	16	597151	FITTING, elbow	3
3	514058	MIXER, pipe 1 in. x 12	3	18	C12509	TUBE, nylon	80
4	158383	FITTING, union, adapter, straight	2	20	104632	VALVE, piloted	2
5	500946	HOSE, 1 in. mbe	1	21	512912	MUFFLER, polyethylene 1/2 npt	2
6	502766	FITTING, cross 1 in. npt(f) sst	1	22	158491	FITTING, nipple	2
7	160327	UNION, adapter 90°	2	23	C20344	FITTING, tee 1/8 brass	1
8	175013	NIPPLE, pipe	4	26	104631	VALVE, foot	1
9	220179	VALVE, check	2	27	522071	SLEEVE, protective; 2.1 ft	1
10	157785	UNION, swivel	2	28	C19391	FITTING, elbow 1/4 npt x 1/4 od tube	2
11	100615	BUSHING, hex steel	1	30	100474	COUPLING; pipe	1
12	156823	UNION, swivel	1	32	512151	VALVE, ball	2
13	214037	VALVE, ball	1	33	215238	HOSE, coupled 61220	2
14	204938	HOSE, coupled, 61120, 25 ft	1	34	241358	KIT, accessory	1

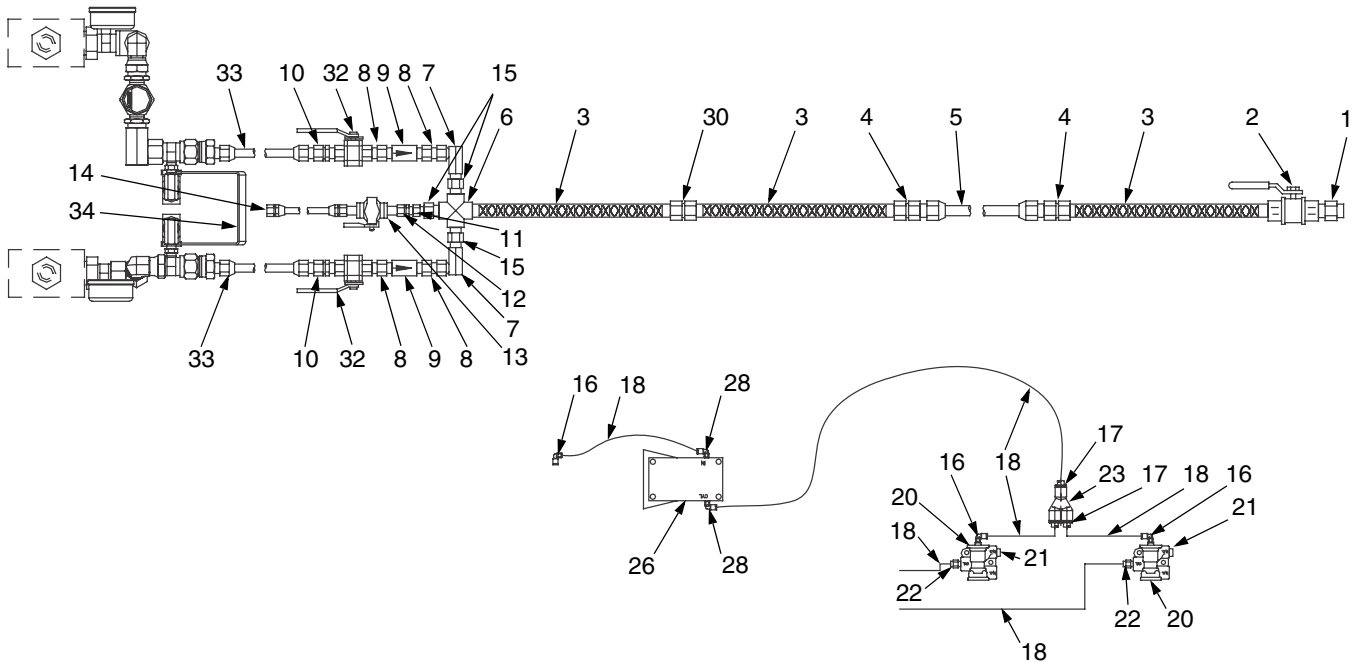

# Stanchion

Module No. 570071

Ref. No.	Part No.	Description	Qty.
1	167636	BASE, ram	1
2	167639	BRACKET, cylinder	4
3	176629	CYLINDER, ram	1
4	166552	CAP, cylinder	1

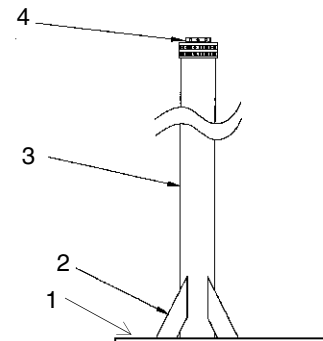
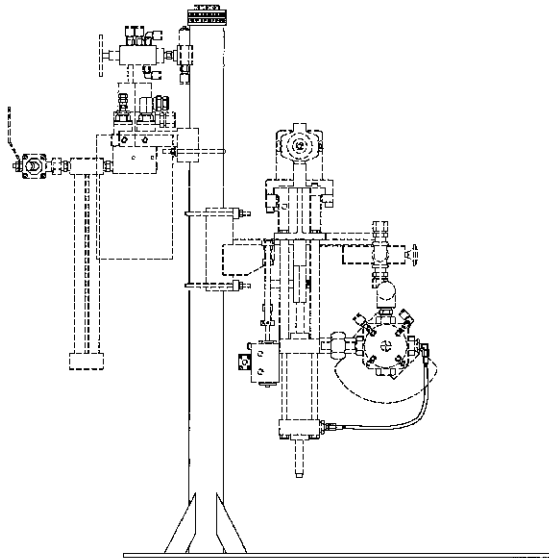

# Boom Assembly

Module No. 246589

Ref. No.	Part No.	Description	Qty.	Ref. No.	Part No.	Description	Qty.
1	947039	FRAME, boom, swivel, 55 gal	1	10	622070	BRACKET, boom	1
2	158383	FITTING, union, adapter, straight	1	11	166590	ELBOW, street	2
3	157262	WASHER, plain	4	13	103473	STRAP, tie, wire	3
4	158555	NIPPLE, reducing	2	14	570071	BASE, stacion mounting	1
5	156971	NIPPLE, short	2	15	606937	FITTING, bulkhead	1
6	155495	UNION, swivel, 90°	1	16	100056	NUT, jam hex	1
7	156175	FITTING, union, swivel	2	17	202966	FITTING, union, adapter	1
8	552231	HOSE, PTFE 1/4 x 12 ft 3000 psi	1	18	100896	FITTING, bushing, pipe	1
9	500946	HOSE, 1 in. mbe	1	19	160032	NIPPLE	1
				20	166999	FITTING, elbow, street	1

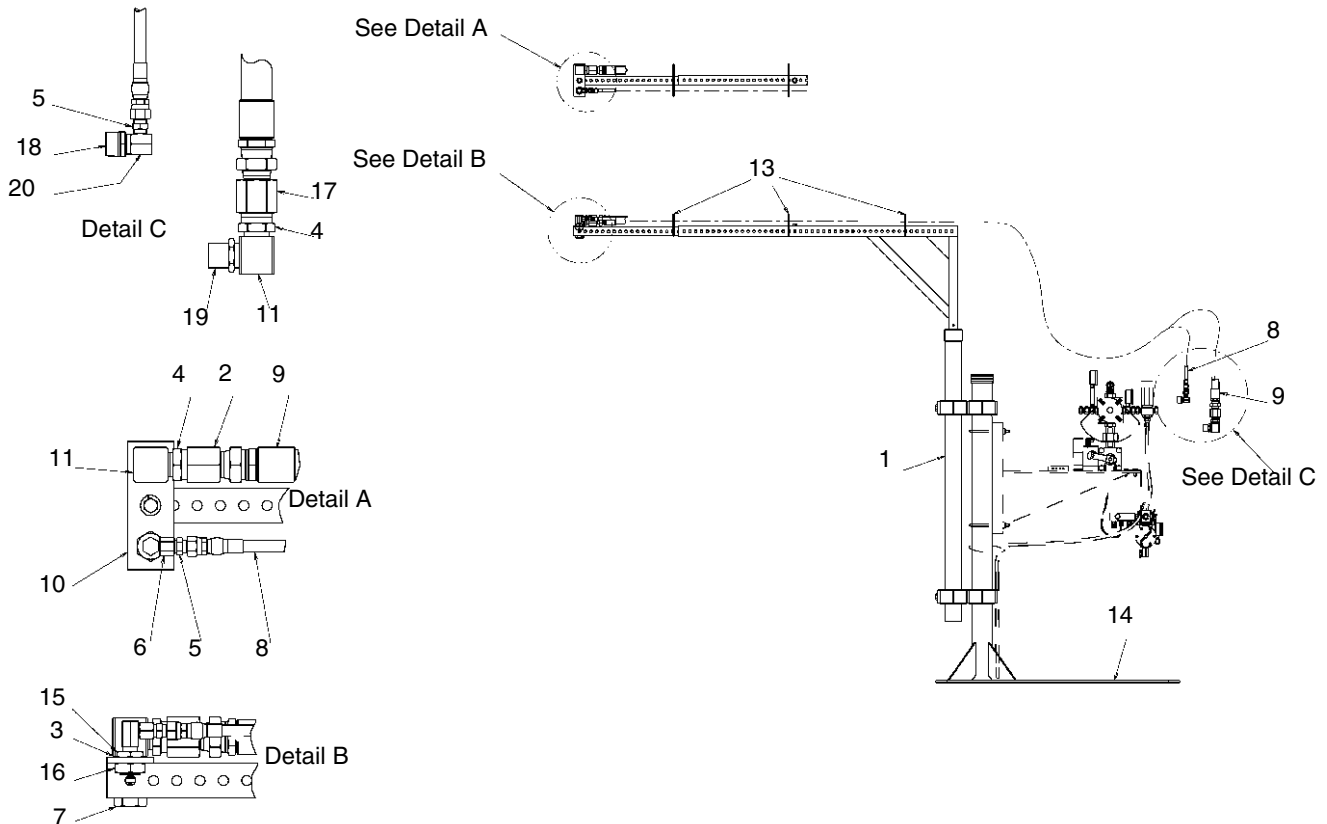



A series of horizontal lines for writing, consisting of 25 evenly spaced lines extending across the width of the page.

# Technical Data

Maximum system working pressure . . . . .	2000 psi (13.8 MPa, 138 bar)
Maximum air input pressure . . . . .	100 psi (0.7 MPa, 7 bar)
Main air inlet size (8900 Proportioner) . . . . .	3/4 npsm(f)
8900 Proportioner outlet size	
Component A Pump. . . . .	3/4 npsm(f)
Component B Pump. . . . .	3/4 npsm(f)
8900 Proportioner inlet size	
Component A Pump. . . . .	3/4 npsm(f)
Component B Pump. . . . .	3/4 npsm(f)
8900 Proportioner wetted parts	Carbon steel, stainless steel, zinc, black oxide, PTFE, fluoroelastomer, electroless nickel, aluminum, nylon

-  • Refer to pump Output Charts on pages 15-17 for ratio adjustment and displacement pump part number information.
- For additional wetted parts information and technical data, refer to your separate component manuals.

## Accessories

570264     President 10:1 mounted on a 5 gallon (19 liter) pail. Used for solvent flush of mix kit assembly.

## Repair Kits for A and B Metering Cylinders

Size	Meter Repair Kit	Cup (Order 2)	Ratio Cylinder	Ratio Kit*
#1000	C24166 or 289402	C05032	C23136	C23041
#500	C24166 or 289402	C23350	C23200	C23087
#250	C24166 or 289402	C23318	C23171	C23067
#111	C24166 or 289402	15C181	15C180	
#100	C24166 or 289402	C22282	C23137	C23042

## Cylinder Repair Kits Cross Reference

289402 Repair Kit EDPM 8900 Cylinder	C24166 Repair Kit	Qty.	Description
15R212	188554	2	PACKING, o-ring
15R213	C20278	2	PACKING, o-ring
C21002	C21002	10	PACKING, vee
C36244	C36244	2	GLAND, male
C36246	C36246	2	GLAND, female

**Repair Kits for All Proportioners**

<b>For Part Number</b>	<b>Repair Kit</b>	<b>Replacement Parts</b>
Actuator 16E287		C24047
4-Way Valve, 3/16 in. C24039	C07067 or 289401	C07069 Trunion 3/16 in. inside port
4-Way Valve, 5/8 in. C24029	C07067 or 289401	C07068 Trunion 5/8 in. inside port.

**4-Way Valve Repair Kits Cross Reference**

<b>289401 Repair Kit EDPM 8900 Cylinder</b>	<b>C07067 Repair Kit</b>	<b>Qty.</b>	<b>Description</b>
15R207	C24032	4	PACKING, o-ring
15R208	C24035	4	PACKING, o-ring
15R209	C24036	4	PACKING, o-ring
15R210	C24040	1	PACKING, o-ring
15R211	103611	2	PACKING, o-ring
15R214*		2	PACKING, o-ring
C24031	C24031	4	SEAL
C24037	C24037	2	BUSHING
C24038	C24038	4	RING, backup

\* This part is equivalent to 105802

# Graco Standard Warranty

Graco warrants all equipment referenced in this document which is manufactured by Graco and bearing its name to be free from defects in material and workmanship on the date of sale to the original purchaser for use. With the exception of any special, extended, or limited warranty published by Graco, Graco will, for a period of twelve months from the date of sale, repair or replace any part of the equipment determined by Graco to be defective. This warranty applies only when the equipment is installed, operated and maintained in accordance with Graco's written recommendations.

This warranty does not cover, and Graco shall not be liable for general wear and tear, or any malfunction, damage or wear caused by faulty installation, misapplication, abrasion, corrosion, inadequate or improper maintenance, negligence, accident, tampering, or substitution of non-Graco component parts. Nor shall Graco be liable for malfunction, damage or wear caused by the incompatibility of Graco equipment with structures, accessories, equipment or materials not supplied by Graco, or the improper design, manufacture, installation, operation or maintenance of structures, accessories, equipment or materials not supplied by Graco.

This warranty is conditioned upon the prepaid return of the equipment claimed to be defective to an authorized Graco distributor for verification of the claimed defect. If the claimed defect is verified, Graco will repair or replace free of charge any defective parts. The equipment will be returned to the original purchaser transportation prepaid. If inspection of the equipment does not disclose any defect in material or workmanship, repairs will be made at a reasonable charge, which charges may include the costs of parts, labor, and transportation.

**THIS WARRANTY IS EXCLUSIVE, AND IS IN LIEU OF ANY OTHER WARRANTIES, EXPRESS OR IMPLIED, INCLUDING BUT NOT LIMITED TO WARRANTY OF MERCHANTABILITY OR WARRANTY OF FITNESS FOR A PARTICULAR PURPOSE.**

Graco's sole obligation and buyer's sole remedy for any breach of warranty shall be as set forth above. The buyer agrees that no other remedy (including, but not limited to, incidental or consequential damages for lost profits, lost sales, injury to person or property, or any other incidental or consequential loss) shall be available. Any action for breach of warranty must be brought within two (2) years of the date of sale.

**GRACO MAKES NO WARRANTY, AND DISCLAIMS ALL IMPLIED WARRANTIES OF MERCHANTABILITY AND FITNESS FOR A PARTICULAR PURPOSE, IN CONNECTION WITH ACCESSORIES, EQUIPMENT, MATERIALS OR COMPONENTS SOLD BUT NOT MANUFACTURED BY GRACO.** These items sold, but not manufactured by Graco (such as electric motors, switches, hose, etc.), are subject to the warranty, if any, of their manufacturer. Graco will provide purchaser with reasonable assistance in making any claim for breach of these warranties.

In no event will Graco be liable for indirect, incidental, special or consequential damages resulting from Graco supplying equipment hereunder, or the furnishing, performance, or use of any products or other goods sold hereto, whether due to a breach of contract, breach of warranty, the negligence of Graco, or otherwise.

## **FOR GRACO CANADA CUSTOMERS**

The Parties acknowledge that they have required that the present document, as well as all documents, notices and legal proceedings entered into, given or instituted pursuant hereto or relating directly or indirectly hereto, be drawn up in English. Les parties reconnaissent avoir convenu que la rédaction du présente document sera en Anglais, ainsi que tous documents, avis et procédures judiciaires exécutés, donnés ou intentés, à la suite de ou en rapport, directement ou indirectement, avec les procédures concernées.

# Graco Information

For the latest information about Graco products, visit [www.graco.com](http://www.graco.com).

**TO PLACE AN ORDER**, contact your Graco distributor or call to identify the nearest distributor.

**Phone:** 612-623-6921 **or Toll Free:** 1-800-328-0211 **Fax:** 612-378-3505

All written and visual data contained in this document reflects the latest product information available at the time of publication. Graco reserves the right to make changes at any time without notice.

*For patent information, see [www.graco.com/patents](http://www.graco.com/patents).*

Original instructions. This manual contains English. MM 309790

**Graco Headquarters:** Minneapolis

**International Offices:** Belgium, China, Japan, Korea

**GRACO INC. AND SUBSIDIARIES • P.O. BOX 1441 • MINNEAPOLIS MN 55440-1441 • USA**

Copyright 2003, Graco Inc. All Graco manufacturing locations are registered to ISO 9001.

[www.graco.com](http://www.graco.com)

Revised March 2013